

TECHNOLOGY EXCELLENCE



45 HIGHTECH
MACHINES

29 AUTOMATION
SOLUTIONS

>30 DIGITAL
INNOVATIONS

CONNECTIVITY
COMPLETED

ADDITIVE
MANUFACTURING



5 digital innovations – for connectivity, open integration & maximum availability.

DMG MORI CONNECTIVITY

5 digital innovations consistent and process-wide 04

myDMG MORI

The new customer portal for service optimization 10

WERKBLiQ

Platform for service and maintenance 12

DMG MORI ECONOMIC PROGRAM

Worry-free investment in turbulent times 14

VCS COMPLETE

Up to 30% higher machine accuracy over the lifetime of the machine 16

CUSTOMER STORY – KAMPF SCHNEID- UND WICKELTECHNIK

Partner for the digital factory 18

INTERVIEW – SPINDLE EXCELLENCE

Fair price guarantee for the quickest spindle repair 20

CUSTOMER STORY – SPN SCHWABEN PRÄZISION FRITZ HOPF

DMG MORI gearSKIVING for complete machining of gears 22

NHX – HORIZONTAL MACHINING CENTERS

The new standard for horizontal machining centers 24

GRINDING – DMG MORI TECHNOLOGY CYCLES

360° Technology Integration 26



Customer story – Three DMG MORI manufacturing systems with a total of eight DMC 60 H ensure maximum machine utilization in 24/7 operation at Zimmer Group.

AUTOMATION – WH FLEX

“Modular automation without limits” 28

DIGITAL TWIN – DMU 340 GANTRY

Step by step to the “DMG MORI Digital Twin” 34

DMG MORI PALLET AGV 50

A vision of material flow with driverless technology 36

INTERVIEW – LPP 160 AND DMC 210 U

Efficient XXL automation for large components up to 6t 38

CUSTOMER STORY – ZIMMER GROUP

Just in time with flexible automation from a batch size of 1... 40

WORLD PREMIERE 2019 – CLX 750

2,000 Nm for heavy-duty turning of workpieces weighing up to 600 kg 42

CUSTOMER STORY – MS ULTRASCHALL TECHNOLOGIE

In-House Production – Attractive pricing of CLX and CMX machines 44

CMX V/CMX U/AUTOMATION

NEW: inlineMASTER spindle for the CMX V and CMX U with 36-month warranty 46

TURN & MILL COMPLETE MACHINING

NTX & CTX TC series 48

CUSTOMER STORY – GE AVIO AERO

Manufacturing capacity doubled 50

CUSTOMER STORY – GKN AEROSPACE ENGINE SYSTEMS

Ergonomic loading of tools weighing up to 30 kg 52



Robo2Go VISION

Production assistant with the convenience of VISION 43

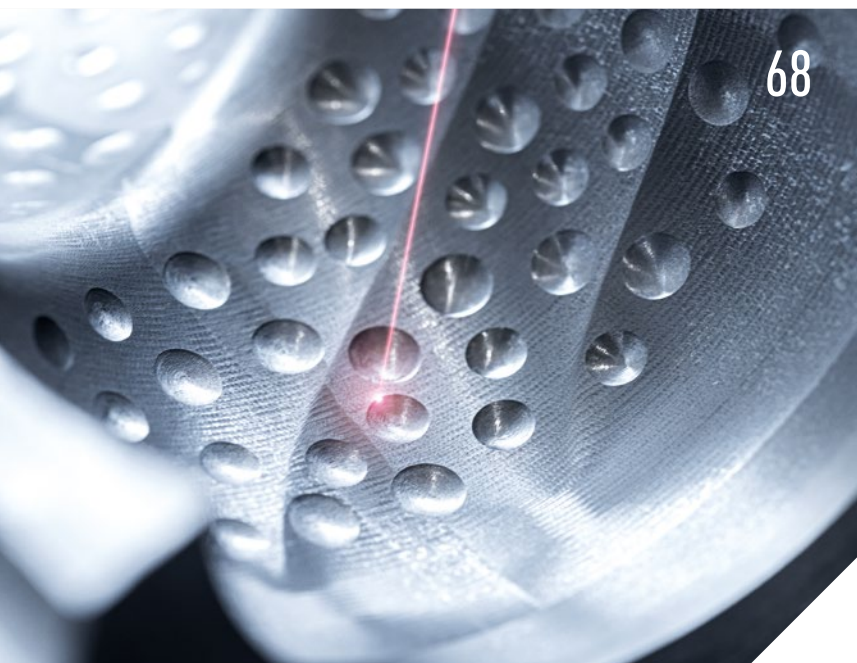

Customer story – Using 180 DMG MORI machines – among them ten HSC 55 *linear* for high-speed cutting and five LASERTEC 45 Shape for surface structuring – OMCO manufactures highly precise glass molds.

ALX 1500/2000/2500

ALX-COMPACT turning machines:
Automated series production 54

CUSTOMER STORY – VOLKSWAGEN AG

Flexibility in high-volume
production at VW in Wolfsburg 56

CUSTOMER STORY – DALIAN RUIGU TECHNOLOGY

100% increase in productivity with the DMC 210 U 58

CUSTOMER STORY – HACK FORMENBAU

5-axis machining around the clock 60

CUSTOMER STORY – SCHAEFFLER TECHNOLOGIES

Rolling bearings and rolling element guidance systems:
Smart key components for higher machine availability 64

DMU 200 GANTRY

Flexible handling of workpieces up to 2,000×1,350mm 66

CUSTOMER STORY – OMCO

HSC and laser structuring
for glass molds with fine details 68

DMQP – MIKRON TOOL SA

New DMQP Partner for high-performance
micro-machining with internal cooling 70

CUSTOMER STORY – MOLL ENGINEERING GMBH

Production of complex surgical instruments 72

CUSTOMER STORY – AZUMA KINZOKU SANGYO

High-precision production of complex forms 74

DMQP POWDER CIRCULATION

Open, continuous, qualified 76

WORLD PREMIERE 2019

Additive Manufacturing – LASERTEC 125 *3D hybrid* 77

DMG MORI ACADEMY

World biggest CNC academy 78

CUSTOMER STORY – MWF TECHNIK GMBH & CO. KG

Machine and finance from a single source 80



“WE CONTINUE TO SPEED UP FOR THE BENEFIT OF OUR CUSTOMERS!”

EMO Hanover 2019 will open in increasingly difficult market conditions. The economic slowdown, geopolitical uncertainties and a weakening automobile industry are leaving their traces on our industry. We also find ourselves in the middle of **deep industrial change**: Automation, digitization, ADDITIVE MANUFACTURING and increasing demand for integrated technological solutions are confronting companies with great challenges.

We therefore continue to speed up for the benefit of our customers and are investing in future-oriented manufacturing solutions and innovative services:

- + 29 of our **45 EMO exhibits** will be demonstrating what can already be achieved today with **automation** – including the modular **WH Flex** building blocks together with **Digital Twin** and the new **PH-AGV 50** driverless transport system.
- + For your “**Integrated digitization**”, we now offer **DMG MORI Connectivity as standard** as well as 30 further innovations.
- + And in the field of **ADDITIVE MANUFACTURING** we will be exhibiting the unique diversity of our continuous and open process chains.

Our new **customer portal myDMG MORI** sets standards in transparent communication, particularly for optimizing service processes for our customers. In addition, we will be supporting you, dear customer, with our “**DMG MORI economic package**” with customized offers for finance, service, used machines and training.

Convince yourself of our **grand display of innovations** live at EMO. We cordially invite you to the **DMG MORI booth in Hall 2** and look forward to meeting you!

Dr. Eng. Masahiko Mori
President
DMG MORI COMPANY LIMITED

Christian Thönes
Chairman of the Executive Board
DMG MORI AKTIENGESELLSCHAFT

5 DIGITAL INNOVATIONS

CONSISTENT AND PROCESS-WIDE

- + **DMG MORI Connectivity:** standard from EMO onwards and free in all DMG MORI machines
- + **CELOS Update:** open integration of the customer's systems and complete update of all existing versions
- + **MESSENGER:** all machines and equipment at a glance
- + **NETservice:** direct remote communication with DMG MORI Service
- + **myDMG MORI:** the new DMG MORI customer portal for service optimization

- + APPLICATION CONNECTOR
- + JOB MANAGER

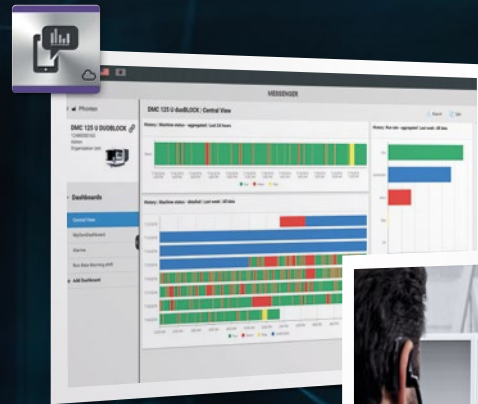
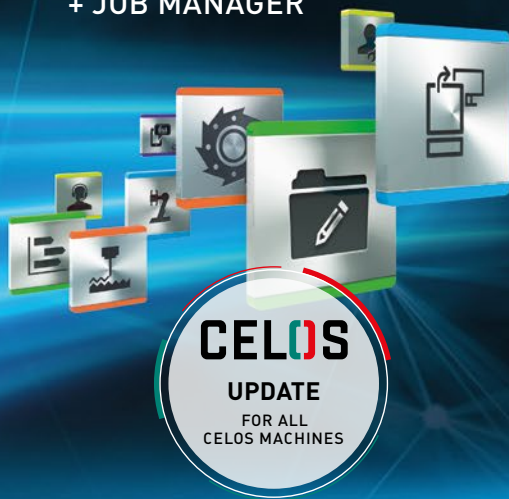

MESSENGER



NETservice

MDA
interface

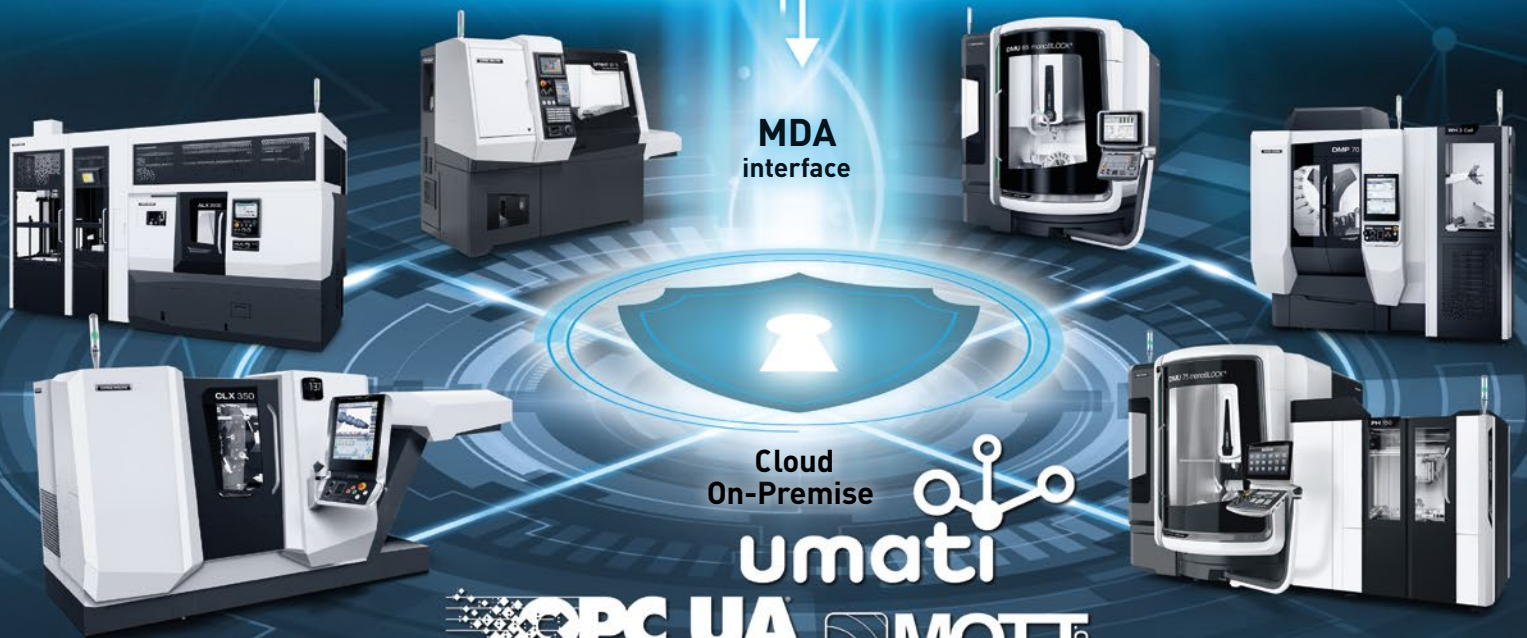

Cloud
On-Premise

umati

OPC UA MQTT
MTConnect

Connectivity is the basic prerequisite for digitization. We provide a machine data acquisition interface as standard for all DMG MORI machines with DMG MORI Connectivity.

Christian Thönes
Chairman of the Executive Board
of DMG MORI AKTIENGESELLSCHAFT



myDMG MORI
CUSTOMER PORTAL

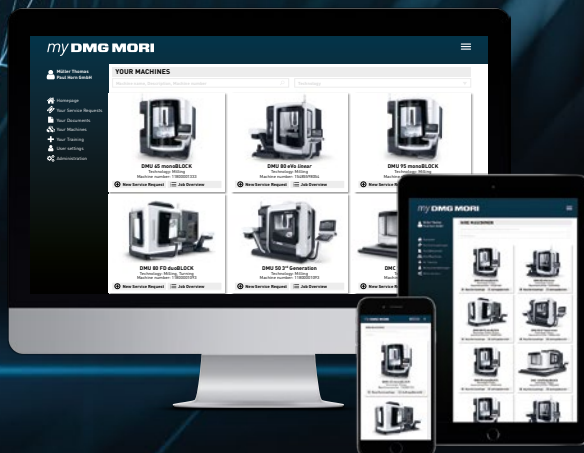

THE NEW, FREE
CUSTOMER PORTAL **myDMG MORI**



In every DMG MORI machine

Mechanical engineering is currently dominated by dynamic alliances. In the interview, Christian Thönes, Chairman of the Executive Board of DMG MORI AKTIENGESELLSCHAFT, explains how the structural change is holistically reflected throughout the portfolio of DMG MORI and which future-oriented innovations customers can expect from the global market leader at EMO.

Mr. Thönes, which digital exhibits and solutions can customers expect on the DMG MORI EMO trade fair stand in Hall 2?

We are presenting more than 30 digital innovations at EMO. With **DMG MORI Connectivity** we are providing secure networking of not only DMG MORI machines but also selected third party machines. In addition, our CELOS customers can also carry out a PLC-independent **CELOS Update** to the 2019 version. This applies to every existing CELOS version from the last six years. The new **DMG MORI MESSENGER** for monitoring now also has an interface for third party software and can be used on all machines and devices in production that are networked with DMG MORI Connectivity. We will be demonstrating live on machines how **DMG MORI NETservice** as a direct remote assistant helps to reduce stoppages. We are exhibiting **myDMG MORI** for the first time, which is our new DMG MORI customer portal for comprehensive service optimization.

Overall we are presenting ourselves as an **end-to-end partner for digitization and automation** and showing how the entire manufacturing process can be consistently digitized with the modular Smart Factory products from DMG MORI, from planning and job preparation to production and on to monitoring and service.

»

*myDMGMORI is only available in member states of the European Union.

What are the special highlights with which you provide orientation?

The focus is clearly on connectivity as far as we are concerned, as it is a basic requirement for digitization and automation. This is why **all DMG MORI machines** will be equipped with connectivity **free of charge in the standard version** from EMO onwards. Every one of our 45 high-tech machines at EMO is also networked.

With DMG MORI Connectivity provide connectivity to DMG MORI and selected third party machines. In doing so, we are supporting all internationally established protocols such as MQTT, MTconnect and OPC-UA, plus the new "umati" language.

DMG MORI Connectivity makes it possible to **connect to all significant IoT platforms** such as ADAMOS, MindSphere, FANUC Field, and others are also possible. The customer chooses the direction and we set up our solutions accordingly. We will be demonstrating this openness and flexibility at EMO in monitoring applications on various platforms.

The massive opportunities that Connectivity presents also involve risks. Our customers expect appropriate security in their production networks so that they are not exposed to malicious cyber attacks on manufacturing systems. During implementation, DMG MORI Connectivity supports a multi-stage "Defense-in-Depth" concept. As secure operation of digital products and handling of customer information is extremely important to DMG MORI, we have integrated an "Industrial Control System", so-called **ICS Security, in our product development as core constituent** of the digitization strategy.

You have just mentioned the new "umati" language. What is so special about "umati"?

The standard is "Key" and "umati" is the new standard in the machine tool industry for open and unrestricted communication within the shop floor and with higher-level IT systems.

DMG MORI has actively promoted, advanced and been instrumental in co-developing the OPC-UA based "umati" standard together with the VDW and selected partners. Now it is a case of establishing "umati" internationally and creating further standards.

How does DMG MORI support its customers with the realization of connectivity and the implementation of digital products?

We have established **DMG MORI Digital GmbH** together with CPRO to provide service and support for all DMG MORI Connectivity solutions.

This joint venture specializes in networking machines. It supports our customers directly on site with advice and qualification and through rapid implementation of digital products from DMG MORI and partners.

What is changing, particularly in the CELOS area?

With CELOS, DMG MORI has been the only machine tool manufacturer with an app-based control and operating system since 2013. We started with 11 apps in 2013, which were mainly for simplifying machine operation. This innovation had been future-oriented and correct. It was followed by expansion of app functionalities with approximately 50 new features per year.

Now, in 2019, we have increased the functionality significantly with a total of 25 apps and have made **open integration of customized systems** possible for the first time.

And we are delivering on our promise to bring all 15,000 installations on the market and all versions from the previous six years to a common level with a PLC-independent update to the **new CELOS version**. The data is safely migrated and all functions supported by the PLC are then fully available.

What exactly is meant by open integration?

The 2019 version of CELOS offers two major innovations. With the new **APPLICATION CONNECTOR**, our customers can use their own applications such as ERP and MES systems or even their own NC and production data management directly on the CELOS-equipped machine. Access to information on the Internet or the Intranet can also be enabled. For example, the machine operator can immediately see shift and holiday plans or information on hazardous substances and important links via the direct connection to the Intranet. In total, up to 20 connections to CELOS can be set up as independent "apps".

And it's quite simple: The customer uses the **SETTINGS APP** to select whether they would like to access the Internet or an application in the system. After making a selection, they determine the connection destination, select a suitable name and a separate icon. At the push of a button, the new connection is then available as a separate "APP" on the user interface of CELOS.

Even deeper integration is made possible with the new **job import functionality of JOB MANAGER**. Orders can be directly imported into CELOS in this way. The customer no longer needs to manually transfer jobs from the MES system into CELOS, but can set up automatic transmission that makes data exchange with CELOS possible. A prerequisite for direct import is that the customer MES system makes the orders available in the job-specific .cba format and stores it in the specified directory within CELOS.

ADAMOS

MindSphere

FANUC FIELD

... and more



In every DMG MORI machine



Openness is also provided with **DMG MORI MESSENGER** at EMO with the CELOS update. For the first time, we are not only offering CELOS functionality for DMG MORI machines but for all devices on the shop floor networked using DMG MORI connectivity, i.e. also for third party machines.

A great deal of customer feedback has augmented the redevelopment of DMG MORI MESSENGER. In this way, the MESSENGER now enables simple machine data acquisition and provides an open database for third party software. Reports can be generated automatically and clearly displayed on a page. The dashboard of the MESSENGER can be configured individually. Customers can see all relevant information about the status of the machines at a glance.

We are convinced that the new DMG MORI MESSENGER is the best monitoring product in our industry.

Monitoring is an important factor for increasing productivity in manufacturing. For this reason, as a **special EMO offer**, users of machines with CELOS will receive the latest CELOS version including the new MESSENGER and DMG MORI Connectivity for their machines as a package. Also included is access to the DMG MORI NETservice limited to 2 years and unlimited access to our new customer portal *myDMG MORI*.

DMG MORI CONNECTIVITY

- + **All machines:** DMG MORI & third party providers
- + **All relevant protocols:** OPC UA, umati, MTconnect & MQTT
- + **All relevant platforms:** ADAMOS, MindSphere, FANUC Field and more
- + **Industrial IT security:** Managed by DMG MORI
- + **DMG MORI Monitoring:** MDA with the DMG MORI Messenger
- + **Integration:** In the customer's shop floor environment by DMG MORI Digital

»

myDMG MORI?

myDMG MORI is our **new customer portal** with which users can organize and optimize all service processes regarding their DMG MORI machines.

Our customers previously had to contact the DMG MORI service hotline by telephone for any request, regardless of whether they merely needed one manual or required a service call. With myDMG MORI, every customer can now send service requests directly online, track the status of the request in real time and access all documents in a comprehensive library, around the clock. Our customers can even view requests that have been dealt with via the NETservice.

In combination with NETservice, myDMG MORI provides comprehensive transparency across all service processes and procedures.

... myDMG MORI can only be used for DMG MORI machines, right?

Of course, the advantages of myDMG MORI relate to DMG MORI machines. However, we also have WERKBLiQ, which is a platform that can also be used for third party products. All information from myDMG MORI is imported and displayed, of course.

WERKBLiQ therefore provides an integrated solution for the digital shop floor for managing documentation in a central location, controlling service operations with precision, implementing maintenance in an effective way and learning continuously through evaluation.

When you talk about the openness of DMG MORI with regards to connectivity with IoT platforms, what role does ADAMOS play in the digital strategy of DMG MORI?

The basic idea of ADAMOS is without alternative, mechanical engineering designs solutions for mechanical engineering, its suppliers and its customers. The **partner network** is expanding continuously, meaning that 16 well-known companies are now actively working together. The implementation of digital applications is supported by the strong network of certified enabling partners.

The exchange of information in the partner network is very positive, as we are united by the firm conviction that we can only deal with the challenges of digitization together. This is how we benefit from Hackathons and

NEW CELOS UPDATE

2013 – START WITH 11 APPS

2019 – INTEGRATED TECHNOLOGIES COMPLETE

- + **PLC-independent:** Can be updated from any existing CELOS version
- + **Reliable migration:** Complete data and functionality preservation
- + **Consistent integration:** Into the existing shop floor environment



APPLICATION CONNECTOR
Remote access to customers' own applications and systems directly from CELOS



JOB MANAGER
Job import function from any MES/ERP system directly into CELOS

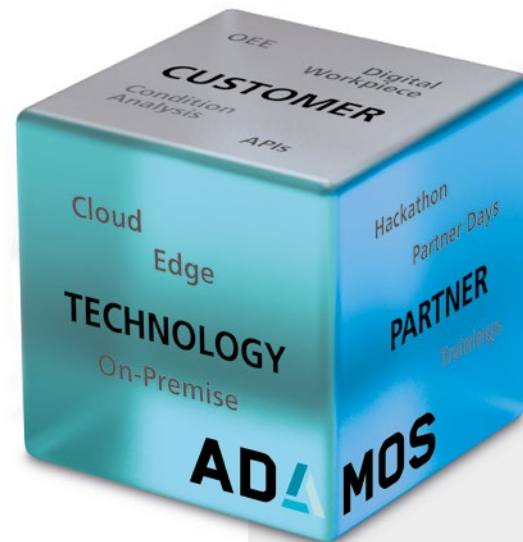

co-innovation projects. Successfully dealing with the digital future together is the main focus of our activities. All partners bundle their know-how in order to understand better and faster the needs of the market. It is important to develop integrated solutions for the digital factory to drive new business models and set standards for the industry. More than 40 product ideas have emerged to date, which have flowed into new services and applications, among other things.

At EMO, ADAMOS is presenting its range of applications for the digital customer experience for the first time via the **ADAMOS APP Store**. Ease of use represents the core of every offer for end users on the shop floor. Machine operators are looking for universal, simple, manufacturer-independent solutions. ADAMOS provides the required tools, technologies and services for a broad and relevant range of digital solutions. The offer includes the first horizontal applications such as the ADAMOS-OEE app, integration with WERKBLiQ from DMG MORI and 10 other solutions.

ADAMOS provides the relevant technology for rapid development of applications with its IoT platform. To ensure that the devices of the DMG MORI Connectivity solution can be managed, DMG MORI uses **"Device Management" from ADAMOS**. Best-in-class products from ADAMOS are used. With "Device Management", DMG MORI connects all machines, systems and devices with the IoT platform.

Which strategy are you following during the development of digital products to market readiness?

Initially we use our digital products internally, learn from users, implement the feedback and then release the result onto the market as a tried and tested solution. For example, customers can convince themselves of the digital maturity of our products by visiting our **digital factory in FAMOT**. 700 employees work simultaneously at 180 work stations with more than 50 machines on up to 11,000 orders in FAMOT. A total of 10 applications are synchronized.

To make this highly efficient manufacturing procedure possible, all processes have been digitized, starting with planning. Whereas we previously needed six employees for manual planning, now two are sufficient. The fully integrated control system makes flexible, detailed planning possible to suit the available capacity. Error-prone planning using Excel can be completely replaced with an automated and integrated system. The basis is an integrated layer that centrally manages all systems.

We also use the WERKBLiQ maintenance platform to control the entire maintenance process of all production machines from a centralized application in FAMOT. We manage more than 60 scheduled maintenance orders per day. The basis for machining on more than 50 installed DMG MORI machines at FAMOT is connectivity.

DMG MORI stands for high-precision machine tools and provides solutions for fully digitized shop floor processes. In this way, we provide a unique basis for actively shaping the future of all facets of manufacturing technology, together with our customers.

It is therefore perfectly clear that we will **continue to invest in digitization**, develop products with a focus on customer benefits and participate in new start-ups if appropriate.

HORIZONTAL INTEGRATION WITH ADAMOS

Collaboration as a **partnership** and the **horizontal integration** of applications are the cornerstones of ADAMOS.

Among other things, collaborative shaping of the future has been attested by the 4 joint Hackathons with more than 250 participants that have taken place, and a total of more than 40 "hacked" product ideas called Minimum Viable Products.

Manufacturer-independent access to applications with full data control by the machine operator is also regarded as a milestone for horizontal networking. In this way, ADAMOS is giving machine operators open and simple access to the innovate strength of digital solution providers via the **ADAMOS APP Store**.

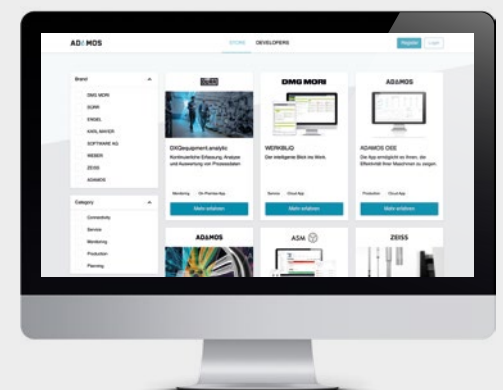

The **ADAMOS APP Store** makes it easy to find and purchase integrated software applications from machine builders and third-party vendors alike.

The new myDMG MORI customer portal offers our customers maximum transparency for all service processes.

Dr. Thomas Froitzheim
Global Service Managing Director



YOUR HISTORY
YOUR MACHINES
myDMG MORI
CUSTOMER PORTAL
YOUR DOCUMENTS
YOUR SERVICE REQUESTS

Free of charge for all DMG MORI customers

myDMG MORI YOUR ONLINE SERVICE MANAGER

The effects of industrial digitization go well beyond the technological aspects. DMG MORI has demonstrated the added value that can be gained in concrete terms with its new myDMG MORI customer portal.

MAKE A SERVICE REQUEST ONLINE WITHOUT HAVING TO WAIT

“The new myDMG MORI customer portal offers fast and direct contact to DMG MORI from any device and includes an overview of the status of all ongoing activities and access

to all documents.” Dr. Thomas Froitzheim, Managing Director of DMG MORI Global Service GmbH, is well aware of the strategic importance of the market leader’s latest digitization initiative.

Access to more service and more knowledge quickly and easily

Efficiency and reliability of service will be supported through myDMG MORI in the future. Customers will then be able to make their service request directly online. “One click on the relevant machine, a short description of the problem with photos or videos if desired, without waiting or misunderstandings on the telephone!” emphasizes Dr. Froitzheim. The request will be sent directly to the “correct” DMG MORI service expert, who will process the request immediately, with the customer able to view the process status live. Moreover,

spare part deliveries can be tracked by “Track & Trace”. No more queries and waiting on the hotline, enabling customers to plan more efficiently and gain a better overview. Every registered customer benefits from holistic transparency. Above all, Dr. Froitzheim’s intention is to fulfil the demands placed by DMG MORI’s customers on the modern portal. “As of now, the central internet address myDMGMORI.com will offer our customers a comprehensive overview of installed DMG MORI machines, ongoing service and spare parts issues as well as the digital provision of relevant documents!”

Digital machine file with lifecycle documentation

“In a way, myDMG MORI mirrors the level of knowledge in our systems,” explains Dr. Froitzheim. In addition to general docu-

TIME SAVINGS WITH PREPOPULATED SERVICE REQUESTS

The machine's historical data will be directly transferred in the service request.

NO QUERIES THANKS TO THE LIVE STATUS

The status of service requests can be viewed at any time.

DOCUMENTS AVAILABLE AT ALL TIMES

All technical and commercial documents can be systematically called up.

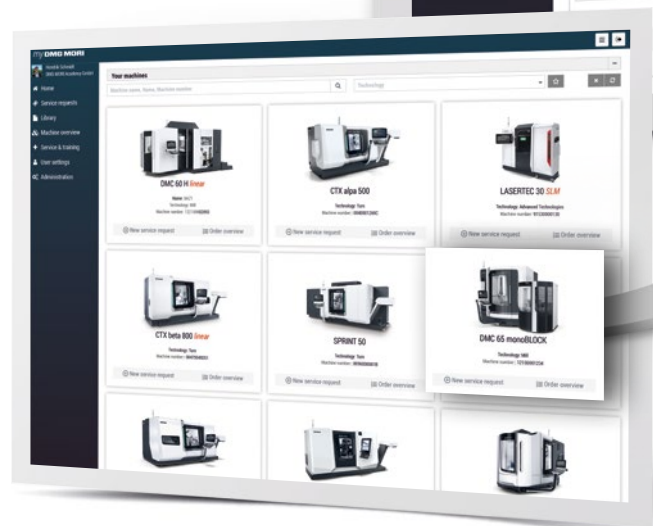
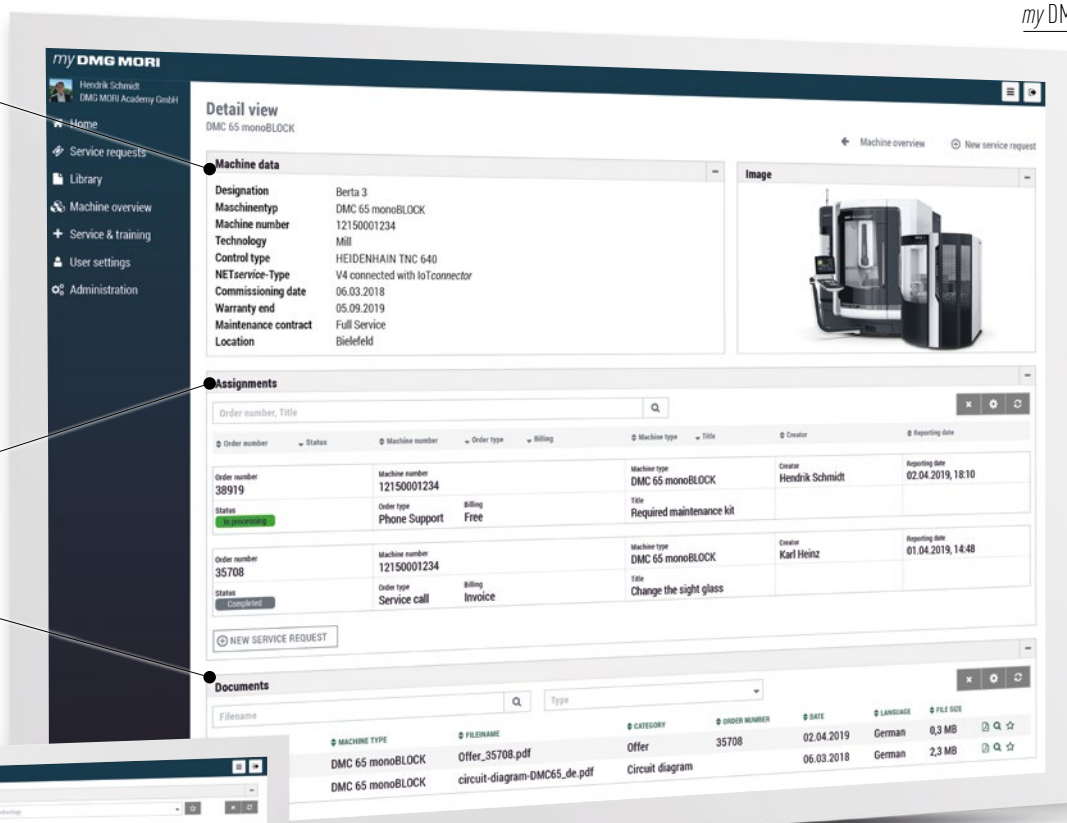

1. Free of charge – register on myDMGMORI.com
2. Fast activation by DMGMORI
3. Automatic completion of the forms including all machine data

myDMGMORI

The new customer portal for service optimization

MORE SERVICE

- + **No waiting:** Simple online description of the problem
- + **Prepopulated service requests:** Include machine details, photos or videos
- + **Immediate processing:** The “correct” service expert prioritizes the request

MORE KNOWLEDGE

- + **Complete machine history:** All events related to the machine can be systematically called up
- + **All documents are digital:** Library for technical and commercial documents available
- + **Real-time access to the process status:** More transparency for service and spare part requests

MORE AVAILABILITY

- + **Free access 24/7:** From anywhere at any time
- + **On every device:** Computer, smartphone or via CELOS
- + **Your portal, your rules:** The customer determines who sees what

ments including instruction manuals for example, the customer library will also include machine-specific lifecycle documentation of every service performed and all spare parts that have been ordered. In the future, the portal will be continuously updated with new options and applications. It will soon be possible to book training courses online and access expert knowhow via an FAQ database.

myDMGMORI on the shop floor

One special highlight that Dr. Froitzheim mentions is the myDMGMORI app. For a service request, the machine will be identified at the push of a button. There is also the option of immediately attaching photos and videos. As a further alternative for the shop floor, myDMGMORI is now standard on CELOS and can now be called up conveniently

via the control. Finally, Dr. Froitzheim would like to pass on some special information: “With an upgrade to WERKBLiQ, third-party machines will also benefit in the future so that all advantages can be realized for the entire manufacturing process.”

«

*myDMGMORI is only available in member states of the European Union.

EASY
REGISTRATION:
myDMGMORI.com

WERKBLiQ

INTEGRATED SOLUTION FOR THE DIGITAL SHOPFLOOR



DMG MORI MACHINES

THIRD PARTY PRODUCTS



Centrally **MANAGE** documents



Precisely **CONTROL** service



Sustainably **IMPLEMENT** maintenance



LEARN continuously through analyses

PLATFORM FOR SERVICE AND MAINTENANCE

Maintenance processes in production are more important than ever, but they cost valuable time and fray nerves. WERKBLiQ simplifies everyday life virtually, at high speed. So customers can keep an efficient grip on their service – internally and externally.

“WERKBLiQ allows machine operators to visualize all structures and processes of maintenance organization digitally and independently of the manufacturer. This includes internal and external communication channels and the entire contract and documentation management”, explains Dr. Tim Busse, Managing Director of WERKBLiQ.

Integrally transparent

As a consequence, WERKBLiQ optimizes the entire service process for all machines and equipment with quantifiable benefits. Even machines without a network connection can be integrated and managed in WERKBLiQ via mobile devices. Incorporation into existing IT systems can be effected quickly and without any great effort on the shop floor. On average, implementation takes just 48 hours.

In their day to day work, employees record and document all activities and processes. They are supported by customizable and interactive windows. All it takes is the press of a button

to alert internal maintenance directly from the machine in the event of a breakdown and to initiate the stored service procedure.

Start free of charge with myDMG MORI – upgrade to WERKBLiQ

myDMG MORI users can easily upgrade their account to WERKBLiQ. All DMG MORI machines are then automatically transferred to WERKBLiQ, where they are integrated and managed holistically with third-party machines and other equipment.

*myDMGMORI is only available in member states of the European Union.



WERKBLiQ – The integrated service and maintenance platform. An end-to-end solution for the shop floor – from the machine to the fire extinguisher.

Dr. Tim Busse
Managing Director
WERKBLiQ GmbH

The networking of WERKBLiQ and DMG MORI SERVICE ensures a particularly high level of customer benefit, as all functions available in the myDMG MORI account are also part of WERKBLiQ.

High degree of customization thanks to digital modularity

In parallel with this, users benefit from all the advantages of the WERKBLiQ platform. They profit from integral functions for managing and optimally controlling the entire maintenance process. This guarantees full control at all times.

Manufacturing companies no longer have to adapt to inflexible software. Individual challenges demand individual solutions. That is why customer-specific configurations were integrated during the development of WERKBLiQ, which can be used by every user to develop their own solution.

“With WERKBLiQ, tasks that today are performed exclusively using paper or Excel can be solved much more efficiently digitally,” says Dr. Busse. Employees at Romaco Kilian in Cologne, for example, save themselves 1.5 working hours a day thanks to no longer having to go back and forth to the workshop so often.

Generation of digital added value for customers

Continuous documentation and recording of data on the shop floor enable end-to-end transparency in subsequent processes. The WERKBLiQ evaluation module means this is no longer just a vision. The module enables maintenance and production managers to evaluate relevant key indicators and use the results continuously to implement improvements.



Simple setup within 48 hours means WERKBLiQ can also be effortlessly integrated into complex IT structures.

Markus Kleiner
Managing Director
H.-D. Schunk GmbH & Co. Spanntechnik KG, Mengen



WERKBLiQ offers our employees additional convenience and saves 1.5 working hours a day.

Heinrich Krull
Head of Operations
ROMACO KILIAN GmbH



ALL myDMG MORI MACHINES ARE ALREADY AVAILABLE IN WERKBLiQ

UPGRADE – YOUR BENEFITS

- + Integration of third-party machines and other equipment
- + Management of the **entire service function. internally and externally**
- + Documentation of all maintenance-related activities **to hand at all times**
- + Identification of **optimization potential**
- + **Simple adaptation** to the customer’s corporate language



THE ECONOMIC PROGRAM FROM DMG MORI FOR WORRY-FREE INVESTMENT IN TURBULENT TIMES



FINANCE – OUR ECONOMIC HIGHLIGHTS

- + Grace period of up to six months at the beginning
- + Staggered rates depending on utilization
- + High residual value of the machines at the end of the finance period
- + Adjustment of the investment figure to finance reconditioning and services
- + Start-up finance to support customers that have recently set up their businesses
- + Flexible contract adjustments even during the fixed term
- + Attractive follow-on financing after the agreed rental period
- + Sale-and-lease-back transactions for additional cash flow

After a long period of growth, many markets are experiencing uncertainty. As a global enterprise with a comprehensive portfolio of machines, DMG MORI is also a strong partner in all economic situations. Less risk for our customers and more trust on our part make us strong together, says Markus Piber, Sales and Service Divisional Director, and Dr. Maurice Eschweiler, Chief Representative of DMG MORI AG, who jointly initiated the program. The DMG MORI economic program has five carefully constructed building blocks. The central DMG MORI advantage: Everything from a single source and perfectly coordinated.

1. Liquidity thanks to buy back

Our customers are always interested in modernization and further development and, in times of uncertainty, there is just as much a focus on liquidity. **This is exactly where DMG MORI comes in with its buy back program for used machines.** In a market otherwise dominated by dealers and with the majority of manufacturers not having their own used machine department, DMG MORI Used Machines has been active as one of the largest CNC machine dealers for many years

and now also handles third-party machines. This means that buy back of used machines including immediate payment is guaranteed for our customers, without having to consult a dealer and wait for a buyer.

2. Risk-free finance

The second building block is a focus on the topic of finance. The DMG MORI Finance program goes far beyond the normal rental, purchase and lease. We guarantee that the customer will not incur any costs before the machine is commissioned. As an alternative, it is possible to **start repayments up to 6 months later**, which offers customers the opportunity to increase their liquidity. The option of rate flexibility related to the utilization of the machine is very interesting. In addition, there are exciting options such as staggered rates, higher residual values, follow-on finance and also sale-and-lease-back. Markus Piber adds that this program naturally also includes investment in automation, used machines and reconditioning and that start-ups are also willingly helped. DMG MORI involvement gets going when banks and other finance institutions have opted out. With this in mind, DMG MORI



It is particularly important to us that our customers can start cutting metal with their machines and earn money.

Markus Piber (top)
Sales & Service Divisional Director,
Dr. Maurice Eschweiler (bottom)
Chief Representative of DMG MORI AG



has launched a "TOP-seller campaign" with competitively calculated lease rate factors and graduated repayments especially for high-volume machines.

3. Training before commissioning

The topic of training is the logical continuation of the first two building blocks. As part of this program, the DMG MORI Academy is committed to **guaranteeing operator training before** the machines are commissioned, irrespective of how short the delivery lead-time is. Customers benefit from perfectly trained employees and can accept orders without delay after commissioning, says Dr. Eschweiler. Naturally, training sessions can be co-financed without any problem.

4. All-round carefree package with full service

Another highlight is the 3-year **all-round carefree package for service** of a DMG MORI machine: Full Service. The package includes a flat rate on all spare parts and service calls, Allianz insurance for crashes and machine breakdowns, and annual maintenance. This means complete planning security with no risk and at attractive prices.

5. Reconditioning: "Never change a running system"

The program also offers an **attractive alternative to buying a new machine – reconditioning**. Many customers are reluctant to switch to new machines due to their knowledge of the existing machines and accessories and their employees' experience. DMG MORI offers a range of options for this – from individual components to complete reconditioning including original spare parts. And DMG MORI also offers the perfect finance solution for this.

«



LIQUIDITY

Immediate payment for buy back of your used machine



FINANCE

Your machine utilization sets the rates



TRAINING

Training before commissioning guaranteed



FULL SERVICE

3-year carefree package, all service costs included



RECONDITIONING

Never change a running system – your attractive alternative

VCS COMPLETE: UP TO 30% HIGHER MACHINE ACCURACY OVER THE LIFETIME OF THE MACHINE

VOLUMETRIC CALIBRATION
AT THE CLICK OF A BUTTON.

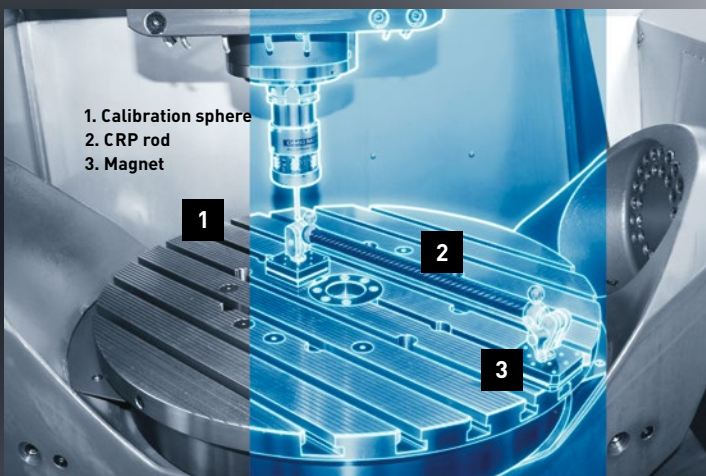

HIGHLIGHTS

- + Up to 30% higher machine accuracy throughout the life cycle
- + Simple compensation of machine geometry
- + Conversational software for quick and easy operation
- + Data recording for further analyses and documentation of the measured results
- + Compensation for deviations e. g. due to wear or collision

NEW: QUICK CHECK

- + The VCS Complete – Quick Check enables fast control over the volumetric geometry of the machine
- + Verification of the measured value within 10 min. 80% time saving
- + Target/actual adjustment using a visual traffic light system



More information about
the technology cycles at:
techcycles.dmgmori.com

*Thanks to its ease of use,
I can check and optimize
the volumetric accuracy
at any time.*

Rolf Ketteimer
Development of technology cycles
DECKEL MAHO Pironten GmbH

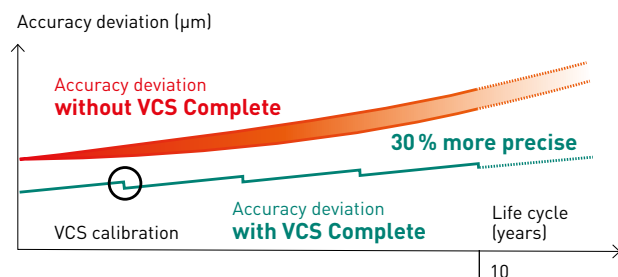

Comparison of accuracy deviation over the life cycle of a machine tool with and without VCS Complete. In addition to initial accuracy optimization, machine accuracy can be optimized over its lifetime with any VCS calibration.

AUTOMATED PROCESSING WITH FIRST-CLASS EQUIPMENT

HIGHLIGHTS

- + First-class equipment at the best price
- + Best accessibility and ergonomics on the market: Complete accessibility to the work area from the front and crane loading from above
- + CELOS with SIEMENS or HEIDENHAIN

PACKAGE CONTENT IN STANDARD VERSION

- + 20,000 rpm speedMASTER spindle with 36 months warranty
- + 60 tool pockets and 3 pallets
- + MPC – Machine Protection Control
- + 100 % connectivity with the IoTconnector



INVEST WORRY-FREE
with the DMG MORI economic package



UP TO 9% SAVING

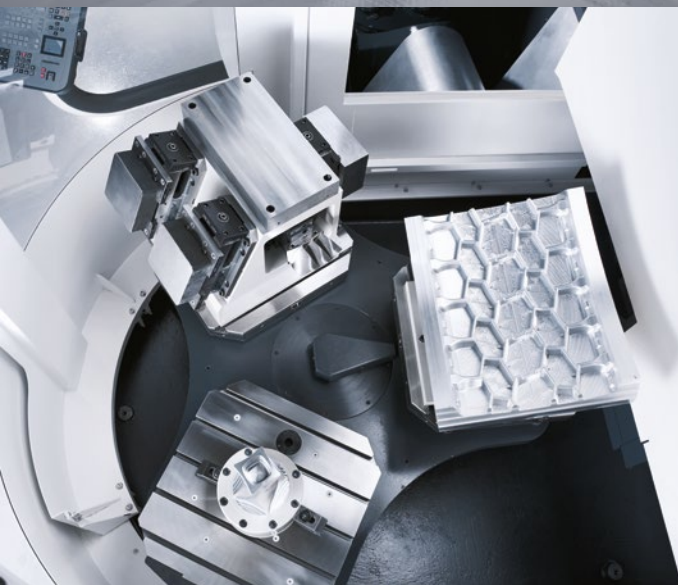

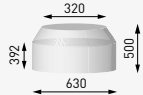
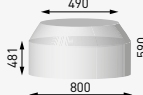
		DMC 75 monoBLOCK	DMC 95 monoBLOCK
Travels X/Y/Z	mm	750/650/560	950/850/650
Pallet size	mm	500 × 500	630 × 630
Maximum load	kg	500	800
Maximum load (crane loading)	kg	600	1,000
Workpiece dimensions	mm		

RPS 3 automated pallet changer for three pallets in a footprint of less than 4m² with optimal accessibility.



With DMG MORI PLANNING and WERKBLiQ and more recently with CELOS and myDMG MORI we have taken a great step forward in the direction of the digital factory.

Dr. Stephan Witt
Head of Engineering & Material Management
KAMPF Schneid- und Wickeltechnik GmbH & Co. KG

Operators of the new CTV 250 can access WERKBLiQ and the new customer portal myDMG MORI directly via CELOS. Feedback of order information can also be sent to the PLANNING SOLUTIONS of DMG MORI directly from the control.



PARTNER FOR THE DIGITAL FACTORY

Since 2015 KAMPF Schneid- und Wickeltechnik GmbH & Co. KG has been rapidly accelerating integral digitization. While the company initially focused its efforts in this direction on its products and services, it is now equipping its production plants for the era of Industry 4.0. To achieve this it entered into a close innovation partnership with DMG MORI in 2017.

The status of the digital innovation process is clearly demonstrated by the KAMPF production site in Dohr, where DMG MORI PLANNING SOLUTIONS has been in use now for several months. "This has made us more efficient and flexible and with a 30% reduction in throughput times we can respond faster", says an extremely satisfied Dr. Stephan Witt, Head of Engineering & Material Management.

High flexibility and fast response

Detailed planning is carried out on the basis of production-related (real-time) information received from the 19 machines and 10 workstations. In this context, Marc Jobelius,

The production planners are supported visually by PRODUCTION COCKPIT. "The clearly arranged visual display enables early identification of delivery delays and their possible impacts, allowing appropriate remedial action", explains Marc Jobelius.

30% REDUCTION
IN AVERAGE
THROUGHPUT TIME

Plant Manager in Dohr, praises in particular the high degree of flexibility and response. Thanks to PLANNING SOLUTIONS, they are now in a position to take the actual capacity of resources into consideration at all times and even re-prioritize process steps while production is in progress.

WITH CELOS into a new era of digital production

KAMPF has initiated entry into the next evolutionary stage of digitization with the installation of a CTV 250 vertical turning center from DMG MORI. "The result is greater integration and interaction between the office and the shop floor or rather between planning, machine tools and our employees", says Marc Jobelius. Thanks to the Job Import function, the operator can import job orders directly from PRODUCTION PLANNING into the CELOS system and start processing them immediately. Also new: PDA information can



CTV 250 WITH CELOS V6

HIGHLIGHTS

- + < 12.5m² footprint, incl. integrated automation and chip conveyor
- + The most powerful turret in its class: **12 driven tools up to 85 Nm and 12,000 rpm**
- + Maximum flexibility: **Workpieces up to ø350 x 200 and 180 mm Y-axis**
- + Top productivity: **8-second loading and unloading time** thanks to twin-track automation
- + Maximum precision: **MAGNETIC linear encoders** in all three orthogonal axes
- + **New in CELOS:** Automatic Job Import and Application Connector-APP

now be fed back directly from CELOS application connector. "Resulting in wide-ranging options for the next level of digitization at KAMPF", indicates Dr. Witt.

OT/IT control loop for data-driven improvement

In other words, the closed data loop will be used in future to bring planning more directly in line with reality. In a nutshell: Where the activities of production planners is currently based on rule of thumb or estimations, "real" knowledge will soon be used to ensure integral predictability for planning in the Dohr plant.

Maximum efficiency with machine learning

In another joint KAMPF and DMG MORI pilot project "real" data from the shop floor is now being recorded in PRODUCTION FEEDBACK and written into a central database via an integration layer. This will ultimately result in an extensive data pool from which realistic projected figures for previously unknown work steps will be calculated using algorithmic pattern matching and then transferred to new planning processes.

«

KAMPF SCHNEID- UND WICKELTECHNIK FACTS

- + Founded in 1920 by Erwin Kampf in Wiehl
- + World market leader for slitting and winding machines for plastic and aluminum foils and composite materials
- + Employees: > 600
- + Export ratio: 90 %
- + Subsidiaries in the USA, China and India as well as international service and sales offices



Kampf Schneid- und
Wickeltechnik GmbH & Co. KG
Mühlener Str. 36-42
51674 Wiehl, Germany
www.kampf.de



You can find the video
to this customer story at:
www.dmgmori.com/kampf

Seamless
integration from
a single source.



Visit us in
hall 9, booth A50



FANUC

www.fanuc.eu



36 MONTH
warranty for all
MASTER spindles
with unlimited
spindle hours

The 11,000 MASTER spindles which leave the factory every year are confirmation of customer satisfaction with the DMG MORI spindle service.

FAIR PRICE GUARANTEE

FOR THE QUICKEST SPINDLE REPAIR

HIGHLIGHTS

- + Fair price guarantee for spindle service
- + More than 6,000 spindles worldwide, available immediately – more than 96% availability from stock!
- + New and replacement spindle service within 24 hours. Alternatively: Cost-effective spindle repair by DMG MORI within a few working days
- + Our spindle experts replace and repair your spindles with a manufacturer's expertise and **only ever use original spare parts**
- + DMG MORI will solve your spindle problem quickly and transparently: **Repairs by third-parties often lead to remedial work!**

Featuring longevity as well as high torque and power, the spindles manufactured and developed by DMG MORI are a key element – the heart of DMG MORI machine tools. In order to ensure that the spindles have maximum availability, DMG MORI provides a unique spindle service, which Dr. Christian Hoffart, Managing Director of DMG MORI Spare Parts, explains in more detail.

Dr. Hoffart, what are the special features of the spindle service from DMG MORI?

We wish to maximize machine availability at our customer sites with our spindle service. The offer ranges from cost-effective repair – with original spare parts, of course – in one of our plants to the installation of new or replacement spindles within 24 hours. We have more than 6,000 spindles in stock worldwide. We therefore achieve availability of 96 to 99 percent on a daily basis. For key machines

we have spindle reservation, the so-called spindle hotel. Our integrated range of services are completed by preventative spindle maintenance, for which we offer a fair price guarantee, unlike third-party providers.

If the customer experiences a crash or damage, what is the ideal (service) procedure?

The damage is reported to the regional service company. This is followed by a damage analysis and spare part identification. Then the service department produces a quote for spare parts and service work, which is confirmed by the customer. Spare part delivery takes place within 24 hours, after which the service department carries out the replacement.

You promise to provide new and replacement spindles within 24 hours. How long does a customer have to wait for a repair on average and what is the average cost saving?

The actual repair of the spindle (from receipt of the goods in the factory) takes about three working days, plus two days for removal and installation of the spindle by a service engineer. The average cost saving compared to a new spindle is around 40 percent.

MORE THAN 6,000 SPINDLES IN STOCK

What role does remote service/remote monitoring of spindles and machines play?

Our NETservice is playing an increasingly important role in spindle service, particularly with regard to automated solutions. Vibration, temperature and torque are monitored with the aid of MPC (Machine Protection Control). The system turns off the machine quickly in the event of a crash. Our service can provide active support by monitoring the MPC vibration data. The customer can also view and evaluate spindle data in real-time using special software solutions.

What basically characterises spindles from DMG MORI in comparison to those from third party suppliers?

Our spindles feature longevity, high torque and power, optimum thermal behavior and low failure rate. Our wide range of spindles

is under continuous further development in order to offer customers made-to-measure, application-oriented solutions. As a spindle manufacturer, we also benefit from this know-how in spindle service, which puts us at least one league ahead of third-party suppliers with regard to quality. We repair using exclusively original spare parts and can rule out the risk of consequential damage. A third party supplier does not have the possibility of supplying brand new replacement spindles. Many customers who have had experience with a third party supplier come back to DMG MORI. Either the quality was not satisfactory or the supposedly better price was significantly higher than our price because of costly reworking – we hear the latter on frequent occasions, by the way. Our experience has shown that all of this leads to a better and longer-lasting result. After all, no-one knows the heart of the machine as well as its manufacturer.

For MASTER spindles there is a 36-month warranty with unlimited spindle hours.

Does this limit only apply to new spindles, or does it also apply to refurbished spindles?

The 36-month warranty only applies to new spindles for the latest machines. Refurbished spindles get a nine-month warranty with unlimited spindle hours.

No-one knows the heart of the machine as well as its manufacturer. We undertake repairs at the fairest possible price.



Dr. Christian Hoffart
Managing Director
DMG MORI Spare Parts GmbH

Do you only offer your service work for new (or recent) machines, or for all machines?

Both technical support and spare part supplies are available for all machines. Our customers expect absolute reliability, maximum workpiece accuracy and longevity. Having customers that are one hundred percent satisfied is the top priority at DMG MORI. Each individual customer is important to us and, therefore, the machines on the shop floor.

«



EXCLUSIVE TECHNOLOGY CYCLE

“ABS FOR YOUR SPINDLE” MPC 2.0 – MACHINE PROTECTION CONTROL

- + Vibration monitoring in the process
- + Switch-off function with teach function
- + NEW: Torque monitoring
- + NEW: Recommended with Protection Package for CTX TC machines
- + Milling spindle bearing condition diagnosis



More information about the technology cycles at:
techcycles.dmgmori.com

DMG MORI gearSKIVING FOR COMPLETE MACHINING OF GEARS



Among other things, SPN Schwaben Präzision produces robots – robot grippers, drive spindles and planetary gearboxes.



With DMG MORI technology cycles it is possible to produce gears in a very short time, and to high accuracy.

Rainer Hertle
Technical Managing Director
of SPN Schwaben Präzision

The story of today's SPN Schwaben Präzision Fritz Hopf GmbH began in 1919 with a mechanical workshop for gear production and contract gear manufacture in Glashütte, Saxony. Today, over 300 employees develop and produce customized drive solutions for the energy, textile and mechanical engineering sectors and increasingly also for the aerospace industry. The diverse range of machines on the shopfloor has been increased since 2015 to include several machine tools from DMG MORI, among them a CTX beta 1250 TC 4A, a CTX beta 800, a DMU 40 eVo, an NHX 4000 and a CLX 450.

"Precision craftsmanship with heart and soul", is the guiding principle followed rigorously at SPN Schwaben Präzision. For Rainer Hertle, Technical Managing Director of SPN Schwaben Präzision, the core values of the company derive from this: "We stand for individual customer orientation, precision and reliability."

Despite coming from different industries, their customers have very similar requirements. The focus is always on durability, maintenance-friendliness and high standards of safety. "We produce gears for landing flaps or undercarriage parts, for example – all safety-critical components", says Stefan Ohmüller, responsible for production technologies at

SPN Schwaben Präzision. The company purchased its first DMG MORI machine tools in 2015. A uniform user interface was one of the determining factors for the purchase. "This makes it easier for our employees to operate several machines", explains Stefan Ohmüller. So, for example, a machinist from the milling section can produce complex workpieces such as robot grippers or ring gears on the CTX beta 1250 TC 4A turning centre. To ensure maximum milling performance, the CTX beta 1250 TC 4A is equipped with a 20,000rpm and 120Nm compactMASTER turn-mill spindle.

DMG MORI gearMILL and gearSKIVING for complete machining of gears

Gear cutting is an essential part of the drive solutions realized by SPN Schwaben Präzision. This is carried out for the most part on special gear cutting machines. However, since 2017 the team has also fallen back on the CTX beta 1250 TC 4A when there are capacity bottlenecks. At that time the machine was retrofitted with the DMG MORI technology cycles gearMILL and gearSKIVING. "With the aid of these cycles we can cut gears at short notice, quickly and with a high level of accuracy", Stefan Ohmüller tells us. In addition the CTX beta 1250 TC 4A offers the possibility of complete processing of gears in a single set-up.



Thanks to CELOS, employees at SPN Schwaben Präzision have fast end-to-end access to all production-relevant information for all technologies, whether milling or turning.

NHX 4000 – speedMASTER spindle with 36-month warranty

SPN Schwaben Präzision boosted its milling capacity in 2018 with an NHX 4000 from DMG MORI. On the one hand the app-based user interface CELOS was once again a deciding factor for the purchase. On the other hand Stefan Ohmüller and his colleagues were impressed by the high level of productivity of the horizontal machining center both in the production of single parts as well as small batches.

State-of-the-art production technology for training purposes

The latest acquisition by SPN Schwaben Präzision was a CLX 450 for the training workshop. "Firstly we can familiarize our young trainees with modern machine tool technology from the very start of their training", says Stefan Ohmüller, "and secondly our training program is production oriented, so a well-equipped, universal turning machine is ideal for this purpose." A 426 Nm and 4,000 rpm spindle drive plus a Y-axis are just two features of the CLX 450.

On the path to a digital future

In their anniversary year, Rainer Hertle is looking to the future: "With our 'SPN goes 4.0' strategy we are addressing the challenges of digitization. From winning new customers through production to logistics, we intend to digitalize and automate our processes as far as possible."

**Exclusive technology cycle
DMG MORI gearSKIVING 2.0**

TURNING – MILLING

- + Straight and helical external or internal spur gears and splines
- + Herringbone gears with tooth offset on turn-mill machines*
- + Gear tooth crowning by mathematical transformation of the 6th virtual axis* on TC machines

*on CTX TC with counter spindle



CUSTOMER BENEFITS

- + Internal teeth possible without an angle head
- + Synchronization and tool path controlled by cycle

**SPN SCHWABEN PRÄZISION
FRITZ HOPF FACTS**

- + Founded in Glashütte in 1919
- + Over 300 employees at today's headquarters in Nördlingen
- + Development and production of customized drive solutions for the energy, textile and mechanical engineering sectors



SPN Schwaben Präzision Fritz Hopf GmbH
Fritz-Hopf-Straße 1
86720 Nördlingen, Germany
www.spn-drive.de



Find out more about the technology cycles at:
techcycles.dmgmori.com

NHX SERIES

THE NEW STANDARD FOR HORIZONTAL MACHINING CENTERS

HIGHLIGHTS

- + **speedMASTER spindles** up to 20,000 rpm or 250 Nm
- + **powerMASTER spindles** up to 16,000 rpm or 1,413 Nm
- + **toolSTAR magazine** with 60 tool pocket or **wheel magazine** up to 303 pockets for **maintime-parallel set-up** (SIEMENS only)
- + **CELOS with MAPPS on FANUC** or **CELOS with SIEMENS** (NHX 4000/5000 only)

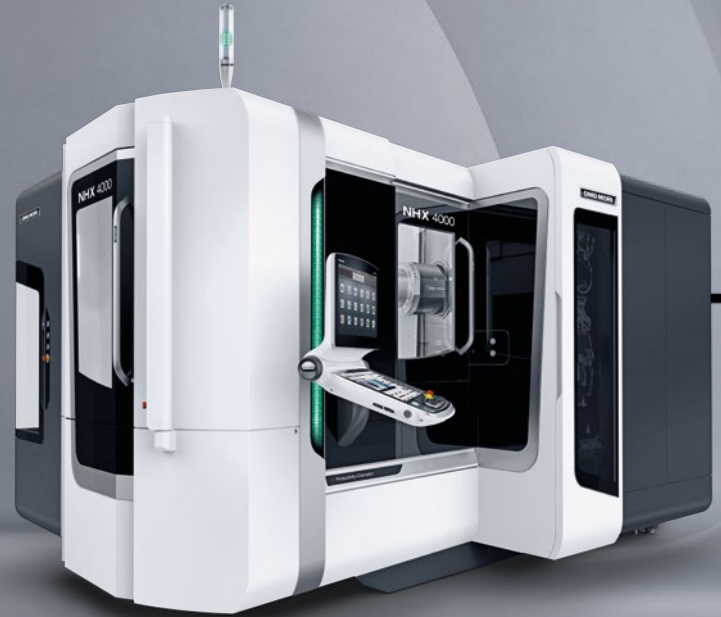

		NHX 4000	NHX 5000	NHX 5500	NHX 6300	NHX 8000	NHX 10000
Pallet size	mm	400×400	500×500	500×500	630×630	800×800	1,000×1,000
load (option)	kg	400	500 (700)	1,000	1,500	2,200 (3,000)	3,000 (5,000)
Max. workpiece	mm	ø 630×900	ø 800×1,000	ø 800×1,100	ø 1,050×1,300	ø 1,450×1,450	ø 2,000×1,600
SPINDLES		speedMASTER (#40/HSK-A63)			powerMASTER (#50/HSK-A100)		
Spindle	rpm	20,000			12,000		
	Nm	221			807		
Spindle option	rpm	15,000			High speed: 16,000 High power: 8,000		
	Nm	250			High speed: 528 High power: 1,413		

AUTOMATION SOLUTIONS

RPS – ROTARY PALLET STORAGE

- + **Rotary pallet storage** with 5, 14 or 21 additional pallets, up to 23 pallets in total
- + **500×500 mm** max. pallet size, **700 kg** max. pallet weight
- + **ø 800×1,000 mm** max. workpiece size



Prepared for unattended production!

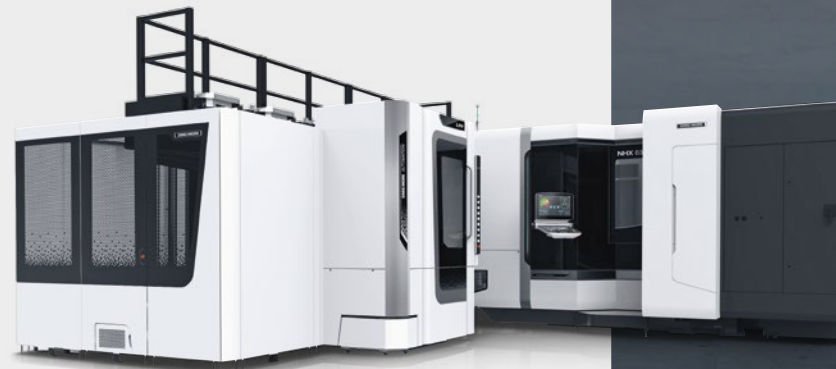

CPP & LPP

- + **500×500 mm** max. pallet size, **700 kg** max. pallet weight
- + **ø 800×1,000 mm** max. workpiece size

CPP – Carrier Pallet Pool

- + Up to 29 pallets
- + Max. 4 machines with 2 set-up stations

LPP – Linear Pallet Pool

- + Up to 99 pallets on 2 levels
- + Max. 8 machines with 5 set-up stations



Tool up for faster payback

Imagine saving up to one year worth of payback time on your new machine investment. With the right approach from the very beginning and the optimal tool set-up for your production, this can be reality in your workshop.

At Sandvik Coromant, we know that collaboration is the foundation for successful manufacturing. We support you, from start to part, to ensure your new machine delivers to its fullest potential.

Let's work together to pay off your machine investment faster.

www.sandvik.coromant.com

SANDVIK
Coromant



TECHNOLOGY INTEGRATION – TURNING, MILLING AND GRINDING

- + **Acoustic sensing through the machine structure** enables dressing and grinding without air cuts
- + **Conversational dressing and grinding cycles** for internal, external and surface grinding (centric) and face grinding (only on milling machines)
- + **Best possible shape and surface quality:**

	GRINDING ON TURNING MACHINES	GRINDING ON MILLING MACHINES
Surface quality Ra	up to 0.1 µm	up to 0.4 µm
Roundness	up to 1 µm	up to 5 µm
Quality	Q 5 with ø > 30 mm	Q 4 with ø > 300 mm

- + Coolant system with integrated centrifugal filter for particle sizes < 5 µm
- + Additional **machine and wear protection** designed for grinding operations
- + **DMQP** – Grinding wheels from TYROLIT



In-process gauging during grinding: Measuring repeatability 5 µm.

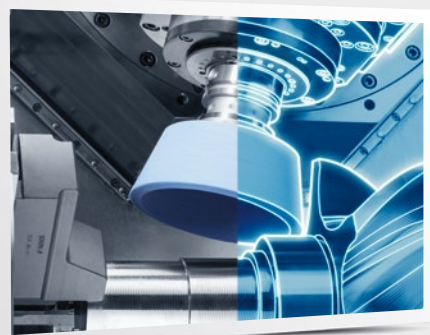

GRINDING ON TURNING MACHINES

- + Available for **CTX TC** and **NTX 2000/2500/3000** with **SIEMENS**
- + **Truing and machining cycles** for straight, angled or cup wheels
- + **External and internal cylindrical grinding and surface grinding**
- + **NEW grinding of:**
 - Eccentric
 - Ellipse
 - Polygon P3G
 - Polygon P4H



A video about the DMG MORI technology cycle can be found at:
www.dmgmori.com/grinding

ATC nozzle unit for targeted coolant supply, automatically exchangeable via the tool magazine.

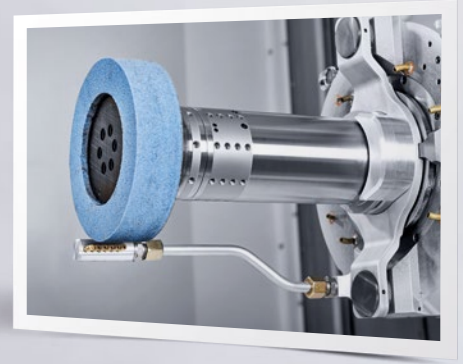

NEW:
Grinding on
monoBLOCK



GRINDING ON MILLING MACHINES

- + Available for **monoBLOCK, duoBLOCK and Portal** machines
- + **Dressing and machining cycles** for surface and cylindrical grinding
- + Stationary or **powered dresser** for dressing of grinding wheels including acoustic sensing through the machine structure
- + **Safe speed monitoring** thanks to diameter measurement via an optical sensor exchangeable from the magazine
- + **Automatically exchangeable grinding wheels** with a max. diameter up to 400 mm

WH FLEX

“MODULAR AUTOMATION WITHOUT LIMITS”

Drip tray



Passive checking station



PERIPHERALS

- + Interim storage for pallets and workpiece fixtures

EXPANSION OPTIONS

- + Passive checking station
- + Active gripping/turn-over station
- + Cleaning station
- + Drip tray
- + Safety barrier

MACHINES

- + Flexible automation for up to 9 DMG MORI high-tech machines or machining centers
- + Integration of machines with alternative technologies

EVERYTHING FROM A SINGLE SOURCE

HIGHLIGHTS

- + **Scalable performance** for automated handling of workpieces and pallets in mixed operation
- + **Variable quantities** in series production
- + **End-to-end solution from a single source** including machines, automation system, application engineering and IIoT integration
- + **User-orientated job management** for efficient planning, control and monitoring
- + **Up to 9 machines** or machining centers for **scalable efficiency and productivity**
- + Individual digital twin development for **maximum security of planning and investment**
- + **DMG MORI's own Cell Controller** for maximum safety and perfect system integration
- + **Electric and pneumatic gripper systems** for workpiece weights up to 7 kg

CELL CONTROLLER

HIGHLIGHTS

- + **Intuitive user interface** with intelligent job management
- + **Grid programming** for simple teaching and setup for handling new components



GRIPPERS

- + Gripper/pallet change system
- + Pneumatic single gripper module for workpiece weights up to 7 kg

EXPANSION OPTIONS

- + Electric double gripper module for workpiece weights up to 3 kg
- + Pneumatic double gripper module for workpiece weights up to 7 kg

ROBOTS

- + 6-axis KUKA robot KR 60 L30-3 for transfer weights up to 60 kg
- + KUKA KR 150, KUKA KR 210, KUKA KR 300 for transfer weights up to 300 kg (optional)
- + FANUC robots (optional)

STORAGE SYSTEM

- + Basic rack with 3 levels; load capacity per level: 500 kg

EXPANSION OPTIONS

- + Rotary rack; load capacity per level: 150 kg
- + Shelves for the basic rack
- + Shelves for the rotary rack; suitable for forklift use
- + Revolving paternoster with 24 trays
- + Bin picking with scanner
- + Storage area for proprietary industrial pallets
- + Storage tower

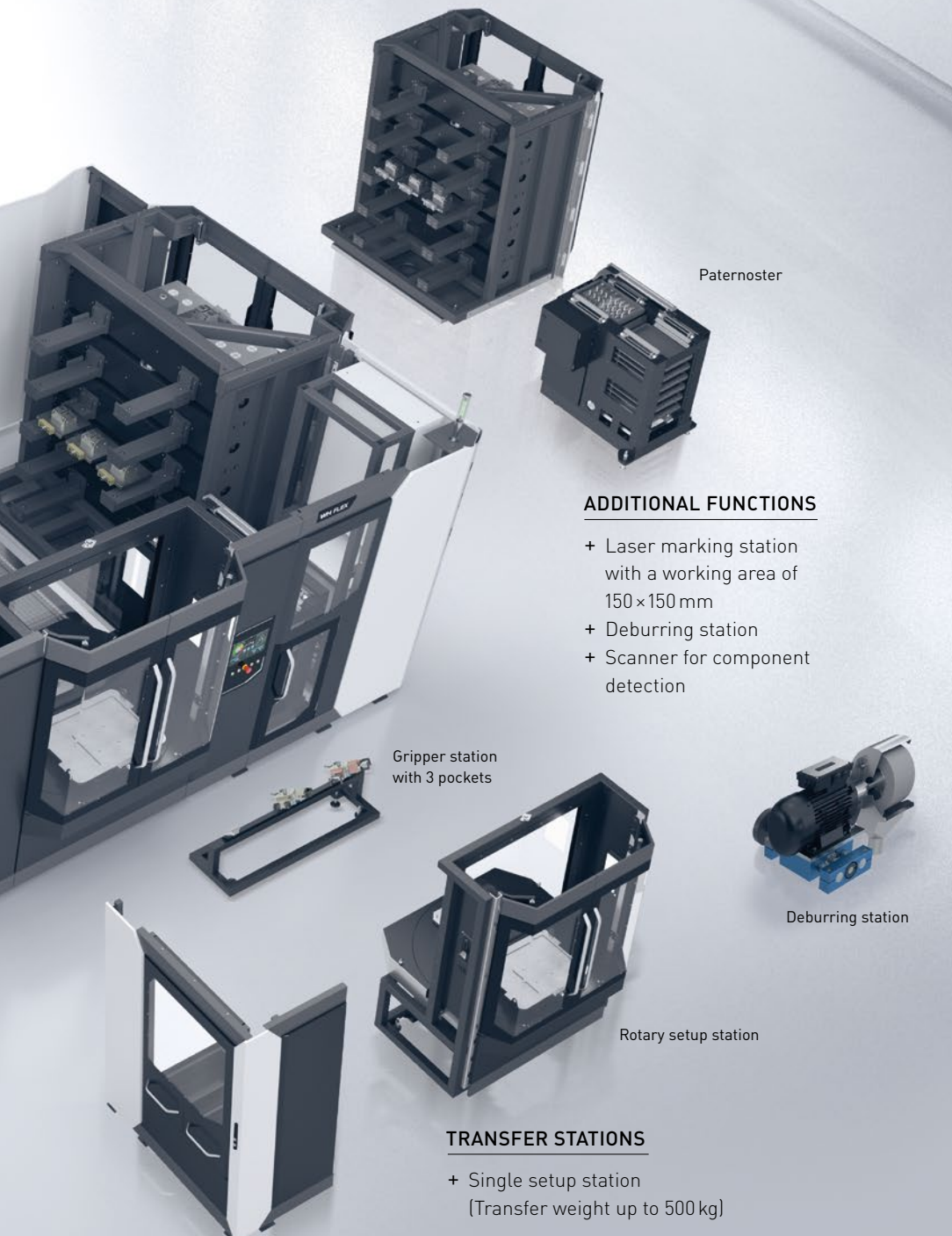

Paternoster

ADDITIONAL FUNCTIONS

- + Laser marking station with a working area of 150 x 150 mm
- + Deburring station
- + Scanner for component detection

Gripper station with 3 pockets

Deburring station

Rotary setup station

TRANSFER STATIONS

- + Single setup station (Transfer weight up to 500 kg)

EXPANSION OPTIONS

- + Rotary setup station (Transfer weight up to 150 kg); Setup during production
- + NOK-/SPC transfer station

NOK-/SPC transfer station

Automation and digitization are two sides of the same coin. No DMG MORI innovation demonstrates this better than the new WH Flex concept that offers maximum flexibility and scalable performance for automated handling of workpieces and pallets.

“No matter what our customers want to do – we go along with it!” With this casual statement Markus Rehm, Managing Director of both DECKEL MAHO Seebach GmbH and the joint venture DMG MORI HEITEC GmbH, expresses in a nutshell the unique character of the new WH Flex concept. Sole constraint: Scalability reaches its limits with nine machines or devices in the system and total workpiece or pallet weights over 500 kg.

**MODULAR
SCALABLE
RETROFITTABLE**

However, in view of the target group of SMEs in the metalworking sector, this is indeed a negligible drawback.

Otherwise, within its scope of operation the WH Flex really does offer “modular flexibility without limits for automatic workpiece and pallet handling”, Kai Lenfer, also Managing Director of DMG MORI HEITEC, proudly announces.

»



You will find a video of the WH Flex at: www.dmgmori.com/wh-flex



WH Flex is a modular building block system offering maximum flexibility and scalable performance for the automatic handling of workpieces and pallets.

Markus Rehm
 Managing Director of
 DECKEL MAHO SEEBACH GmbH and
 DMG MORI HEITEC GmbH
 markus.rehm@dmgmori.com



DIGITAL TWIN

HIGHLIGHTS

- + **Digital Twin as cybernetic image** of the automation system with virtual controls and interfaces
- + **Time and cost saving** thanks to development-based product optimization
- + **Up to 80 percent faster commissioning** due to real-time simulation of all processes and procedures
- + **End-to-end connectivity** for vertical and horizontal system integration
- + **High level of investment security** thanks to Digital Twin-aided tendering

Automated turning up to 6-sides and milling in up to 5 axes simultaneously? Deburring, washing, drying, checking? Workpieces and pallets in mixed operation? All no problem at all. Only the raw material and pallets have to be adapted to the gripper stations. All other processes are carried out by the WH Flex system, right through to the finished part.

Automation concept with convincing performance

As a classic example of implementation the EMO exhibit integrates a DMP 70 vertical machining center and a 5-axis DMU 40 eVo center to form a highly flexible manufacturing system for automatic complete machining of a mixed variety of workpieces.

The WH Flex concept is based on an extensive set of building blocks that include a number of standard options. The portfolio includes various storage systems such as racks, pater-nosters and pallet stations.

These can in turn be combined with different gripper and gripper change systems as well as other options such as SPC-based component removal or positioning, turn-over and cleaning stations. The possibility of integrating various applications, for laser marking, for example, or measuring and testing, underscores the customer-oriented solution approach.

“Unique solution offering”

However, it is not simply the modular building block concept that makes the WH Flex a “unique solution offering”, as Markus Rehm, Managing Director of DECKEL MAHO Seebach GmbH and DMG MORI HEITEC GmbH, stresses: “As a one-stop, turnkey partner we supply the high-tech machines together with the automation technology as well as all special customized equipment and components. These include controls, fixtures, the tooling and NC programs – right through to the integrated automation and digital connectivity.” It goes without saying that service,

3 HIGHLIGHTS FOR THE FUTURE OF MANUFACTURING

maintenance and replacement parts all come from a single source as well. According to Markus Rehm there are three other factors that contribute to the uniqueness of the overall picture, over and above the end-to-end approach. “Firstly the digital twin, secondly, horizontal and vertical networking and thirdly, the proprietary CELL CONTROLLER, whose operation is not just intuitive but also offers outstanding features for flexible production.”

»

WH FLEX BASIC CONFIGURATION

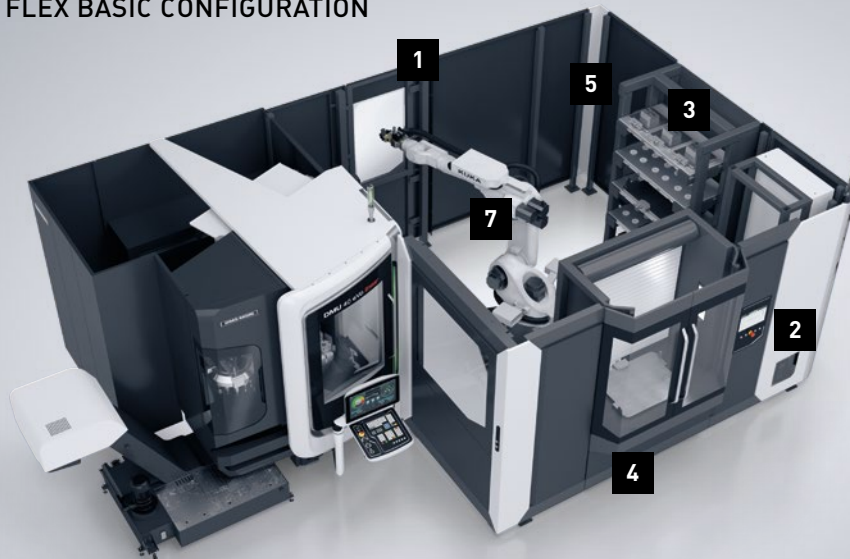

EQUIPMENT

1. Protective guard with access door
2. Basic cell control with HMI touch panel
3. Basic rack
4. Basic setup station
5. Single gripper module
6. Control cabinet with control system and basic sensor system as well as basic pneumatics
7. KUKA robot KR60
8. Storage for pallets

TECHNICAL DATA

Footprint: 4,520 × 4,115 mm (without machines)
 Transfer weight: 60 kg
 Robot radius of action: 2,429 mm
 Basic rack with five shelves
 Basic setup station designed for max. pallet size of 800 × 600 mm

WH FLEX EMO SHOWCASE

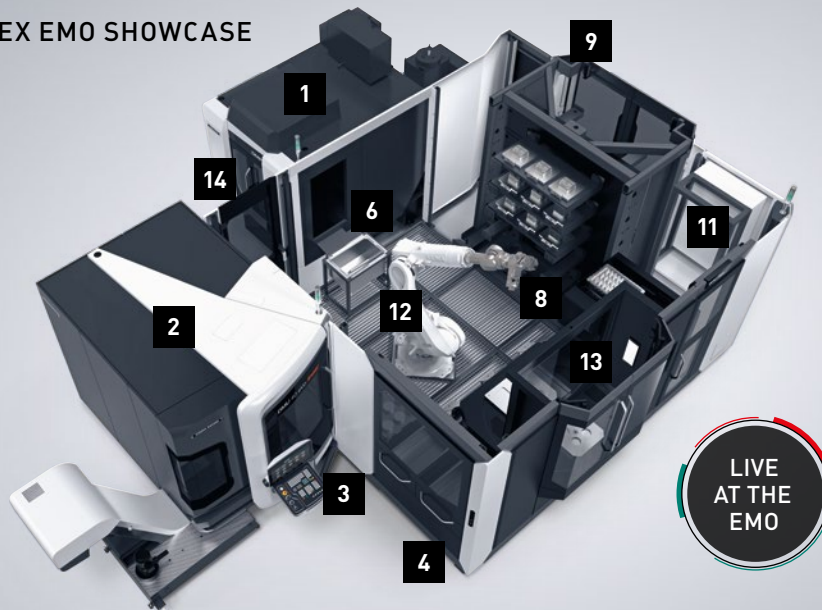

CONFIGURATION EXAMPLE

- | | |
|--------------------------------------|---|
| 1. DMP 70 | 9. Rotary rack |
| 2. DMU 40 eVo | 10. Paternoster |
| 3. NOK drawer | 11. Control cabinet with control system and basic sensor system as well as basic pneumatics |
| 4. SPC drawer | 12. KUKA robot KR 150 |
| 5. Passive checking station | 13. Rotary setup station |
| 6. Cleaning station | 14. Protective guard with access door |
| 7. Active gripping/turn-over station | |
| 8. Double gripper | |

- + Basic cell software
- + Grid programming

TECHNICAL DATA

Footprint: 5,288 × 4,562 mm (without machines)
 Transfer weight: 150 kg
 Rotary rack with five shelves
 Rotary setup station with two pallet locations
 Paternoster with 24 trays (effective revolving use)

WH FLEX LINE

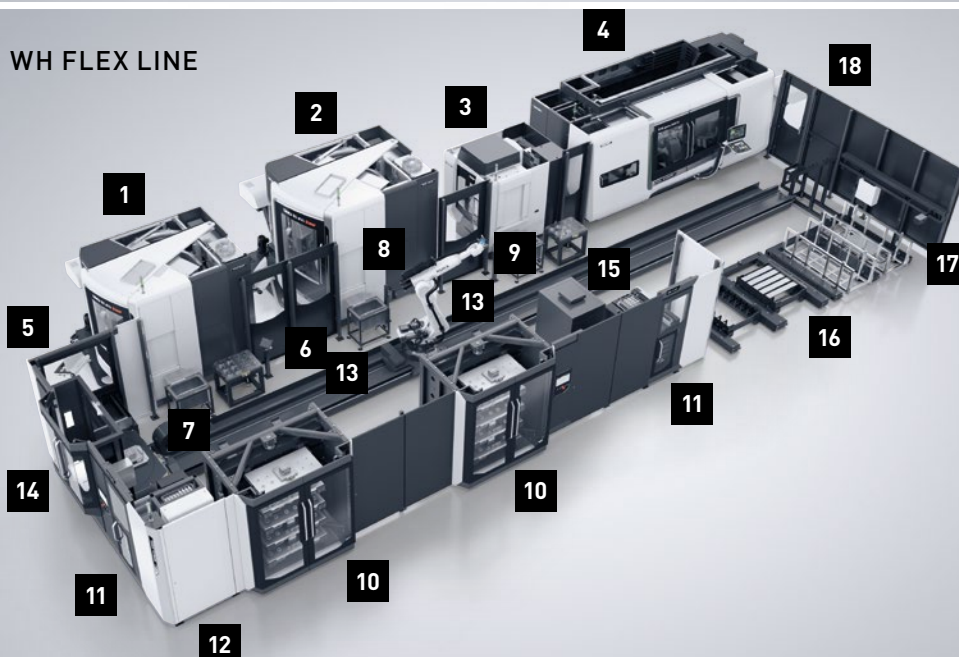

CONFIGURATION EXAMPLE

- | | |
|--------------------------------------|---|
| 1. DMU 60 eVo | 11. Paternoster (2×) |
| 2. DMU 80 eVo | 12. Control cabinet with control system and basic sensor system as well as basic pneumatics |
| 3. CMX 800 V | 13. KUKA robot KR 300 on linear seventh axis |
| 4. CTX beta 2000 | 14. Rotary setup station |
| 5. NiO/SPC drawer | 15. Laser marking unit |
| 6. Passive checking station (3×) | 16. Pallet magazine |
| 7. Cleaning station (3×) | 17. Scanner |
| 8. Active gripping/turn-over station | 18. Protective guard with access door |
| 9. Double gripper | |
| 10. Rotary rack (2×) | |

- + Basic cell software
- + Grid programming

TECHNICAL DATA

Footprint 20,000 × 6,000 mm (without machines)
 Transfer weight 150 kg
 Rotary rack with five shelves
 Rotary setup station with two pallet locations



DMU 60 eVo *linear* WITH WH 15 CELL

SYSTEM HIGHLIGHTS

- + Modular building block concept for application-oriented system configuration of machine and automation
- + Dynamic machine concept for a high level of productivity and precision
- + 5-axis simultaneous milling for complex tasks
- + Efficient complete machining in a single setup

DIGITAL TWIN

- + Fast commissioning and maximum reliability
- + Virtual simulation and optimization of machining processes and system sequences

The entire WH Flex system is planned, controlled and monitored via an intuitive user interface and intelligent job management. "So no special knowledge or training is necessary for operation," says Rehm.

He mentions exemplary features such as grid programming for simple teaching and setup for handling new components or job management for preparing urgent orders.

Modular concept for up to 9 machines

"Apart from the soft features, it is the extensive range of possibilities for workpiece and pallet handling for up to 9 machines via the modular WH Flex system that is so impressive", adds Kai Lenfert, also Managing Director of DMG MORI HEITEC.

In the same breath he goes on to point out another special feature, the integrated gripper change. This enables the productive handling of both workpieces and pallets in the WH Flex system.

In this case it is a KUKA robot that acts as the handling device. Kai Lenfert is convinced: "Our small to medium-sized customers in particular benefit from the future-oriented option for entry into flexible automation that we provide for them with the WH Flex modular building block system, especially as all machines within the system remain fully accessible and the customer can grow with the system."

Consistent virtualization from the design through to the application

Markus Rehm, too, is optimistic and has high hopes for the DMG MORI Digital Twin: "With the aid of the digital twin – a cybernetic image of the real configuration – the system can be put into virtual operation before actual installation – including real-time simulation of all processes and procedures. This sustainably reduces the costs of engineering, comprehensively boosts the quality of the system and saves up to 80% of the time that would otherwise be needed for commissioning."



DMP 70 WITH WH 3 CELL

HIGHLIGHTS

- + **Automated 5-axis production machine** for highly dynamic workpiece handling up to 3 kg
- + **Top rigidity in this class** for stable milling and maximum accuracy
- + **Compact automation** with a minimum space requirement of just 10.65 m²

The user will additionally have the option of testing new workpiece/pallet setups virtually while production is running, adds Kai Lenfert. Especially where SMEs are concerned, this additional benefit could contribute significantly to securing the investment decision.

«

HAIMER i4.0 – Technologies for smart Production

HAIMER
Quality Wins.

Sep 16 – 21, 2019

Visit us in Hanover!
Hall 4 | Booth E16

EMO
Hannover



Tooling Technology

Shrinking Technology

Balancing Technology

Measuring and
Presetting Technology

www.haimer.com

DMU 340

STEP BY STEP TO THE
“DMG MORI DIGITAL TWIN”

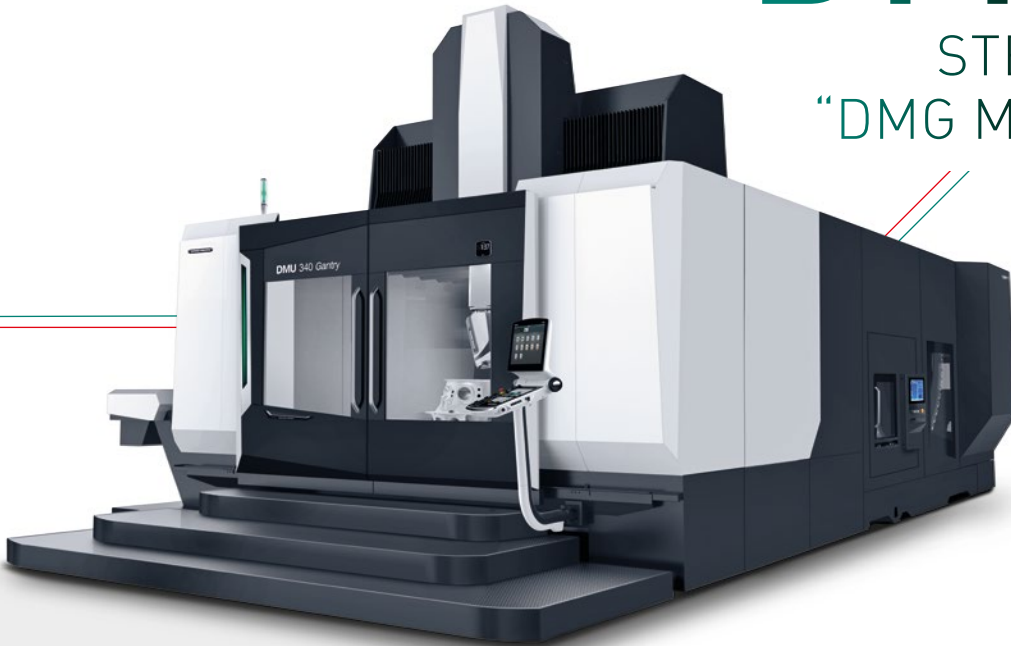

DMU 340 GANTRY

HIGHLIGHTS

- + **Double pinion rack and pinion drive** – in X- and Y-axis or optional linear drive for outstanding surface quality (down to Ra 0.3 µm)
- + **±300° C-axis** positioning at up to 40 rpm and direct drive for highly dynamic 5-axis simultaneous machining
- + **One piece, inherently rigid machine bed** made of GGG 60 for maximum rigidity and effective damping
- + **Modular wheel magazine** for up to 453 tools and chip-to-chip times < 15 s with maximum tool length of 650 mm
- + **B-axis with 50° swivel** and direct drive for machining angles of up to -10°
- + **Powerful motor spindles** with up to 430 Nm or 30,000 rpm for efficient roughing and finishing

The technology of “digital twins” was first mentioned at the University of Michigan in 2002. 17 years later, digital representations are regarded as the industrial future. The topic is also high on the agenda at DECKEL MAHO Pfronten – especially in the area of product development and particularly as far as the DMU 340 Gantry is concerned.

The first step on the way to the “Digital Twin” is to create a dynamic model of the machine and equip all of the key components and all dynamically sensitive structural elements of the virtual machine with sensors. A functional likeness that reflects all of the characteristics of its real counterpart comes into being when interaction takes place with the PLC and CNC, which are also virtualized.

The behaviour of the “Digital Twin” can now be simulated, analyzed and evaluated in detail during a wide variety of operational situations. Feedback of the simulated knowledge into the real world then takes place “in the loop” until the optimum result has been achieved. “Valuable knowledge can ultimately only arise from new knowledge using an iterative improvement process such as this”, emphasizes Alfred Geißler.

With the DMU 340, knowledge impressively manifests itself in iron and steel and also in bits and bytes – in reality and also virtually.

In the loop for practical iterative improvement

“However, the digital twin will ‘only’ continue to be applicable while time is being saved and quality is improving in our product development”, emphasizes Alfred Geißler. In this way, the “memory” of the digital twin increases with every simulation of a wide variety of scenarios and requirement profiles and every applied increase in knowledge. Gradually, this learning process is intended to lead to a situation whereby the “Digital Twin” will recognize anomalies from its own experience and therefore be able to provide more specific information for continuous improvement.

“In the loop” for a perfect process

Evolution to the “Digital Process Twin”

“In the evolutionary interaction, a Digital Process Twin will finally develop from the Digital Machine Twin”, says Alfred Geißler and explains: “The process twin creates the link between product development and customer added value.”

In this context, Alfred Geißler first refers to the effect on collaborative application development, which has almost become a standard procedure in Pfronten, particularly (but not only) in complex 5-axis machining.

Thanks to the “Digital Process Twin”, in future it will be possible to virtually assemble new machines down to their individual components in Pfronten before delivery to the customer. “According to our experience

with the virtually mirrored DMU 340, we are convinced that the time for commissioning at the customer's premises and the start of production can be reduced dramatically", says Alfred Geißler.

The mirror image of the twin to the digital factory

He also refers to the clear DMG MORI road map of the way forward, from the clearly desirable added value all the way to new business models. The idea is for it to be possible soon for the customer to holistically evaluate new workpieces from the CAD data alone, says Geißler about the future prospects.

In this way, customers will be able to virtually generate and simulate NC programs in the mirror image of the twin, investigate workholding solutions, test tools, create time studies and (more or less in a digital instant) submit reliable quotes. "In conjunction with ERP and MES systems, it could be done on demand with a fixed delivery date", stresses Alfred Geißler.

This in turn opens up the new world of the "On Demand" and "As a Service" economy. However, Alfred Geißler also sees major opportunities for the DMG MORI business, particularly in service and especially in the area of predictive maintenance. "Because whoever can simulate the future will always know what to do in the present", is his concluding summary.

«



Alfred Geißler
Managing Director
DECKEL MAHO Pfronten GmbH



INTERVIEW – DMG MORI DIGITAL TWIN

DIGITAL FOR MORE KNOWLEDGE, ADDED VALUE AND GROWTH

Where do you see the strengths of the digital twin for manufacturing technology?

In the first instance, the simulation models of the "DMG MORI Digital Twin" allow us to optimize characteristics and functions during development.

The secret of developmental optimisation lies in deriving the right algorithms from the recorded data and simultaneously incorporating them into product improvement.

In the virtual engineering that follows, we also achieve a high degree of maturity of individual customer machines, processes and systems – leading to short commissioning times and a prompt start to production.

To what extent can the customer benefit from the subsequent use of the DMG MORI DIGITAL TWIN?

It will soon be possible to make the processes in the real machine more transparent, easier to interpret and more and more predictable through the continuous acquisition of real data and linking it directly to the "DMG MORI Digital Twins".

The added value of the digital twins will increase with the willingness of customers to enter into a collaborative alliance to share the data as the basis for joint analyses.

Our goal for the near future is therefore to implement the DMG MORI Digital Twin together with our customers over the entire lifecycle.

New knowledge, added value and ultimately growth potential can only be realized by in-depth quality data from our machines and transparent insights into customer processes in combination with modern analytics.



A VISION OF MATERIAL FLOW WITH DRIVERLESS TECHNOLOGY

DMG MORI
powered by **JUNGHEINRICH**

PH-AGV 50

HIGHLIGHTS

- + Flexible automation concept
- + Free access to the machine
- + Simple extension with additional machines
- + Maximum safety due to laser scanners
- + Transportation of machine and material pallets

Automation of material flow

“And the more we deal with the topic, the more intralogistics becomes the main focus of the holistic view. For this reason driverless transport systems, otherwise known as Automated Guided Vehicles (AGV), are becoming increasingly important as a means of material flow,” says Michael Horn.

This is knowledge that is increasingly in evidence in the factory buildings of DMG MORI’s global production locations. The consistently positive experiences and effects have obviously also inspired the company’s own product development.

Modular kit from DMG MORI

including proprietary computer technology

The PH-AGV 50 product includes a comprehensive kit for individual configuration – including DMG MORI’s own MCC-LPS control computer. Warehouse modules that can be extended in a modular way ensure efficient organization and correct material flow. There is also 2-way intermediate storage station to ensure short pallet change times. Standard machine pallets can be handled by the AGV system, such as special zero point clamping pallets and conventional material pallets, of course. Also very important: Since the AGV manoeuvres and positions without guide rails, the machines are always freely accessible.

PALLET HANDLING WITH FREE ACCESS TO THE MACHINE

For a long time, mechanical engineering concentrated its innovative strength on mechatronics, control technology and integrated automation. However, the perspective opens up appreciably with digitalisation and now also includes material flow as a fundamental part of integrated production.

Michael Horn, board member for production, logistics, quality and IT at DMG MORI AG, thinks in an interdisciplinary way and knows from experience: “The core question in many companies is no longer how you obtain a component from a machine better, faster and more accurately. It is more a question of how machines, tools, materials and processes can be combined into a perfectly coordinated value creation solution.”

From our own practical experience to the customer’s factory

At EMO, DMG MORI presents the modular PH-AGV 50 system, which was developed in partnership with Jungheinrich. Starting next year, this system will be available to enhance the logistics in customers’ factories all over the world as well as in the Group’s own production plants.

With the introduction of the driverless transport system, the flexibility of the production process and thus also its productivity can be increased. At the same time, it is possible with these systems to reduce handling time and costs. The payback period is expected to be less than 1.5 years.



Because of the freely configurable layout and simple extendibility, the AGV system can be effortlessly integrated into existing production areas.



Cornelius Nöb
Managing Director
DECKEL MAHO Pfronten GmbH

Shop floor value creation partner

For Cornelius Nöb, managing director of DECKEL MAHO Pfronten GmbH, the PH-AGV 50 is the answer to a changing market: "Customers expect far more from us as a machine tool manufacturer than the machine alone or workpiece-oriented application engineering, particularly since the upsurge in digitization.

On the contrary, nowadays we are a solution-oriented shop floor value creation partner. The development of our own driverless transport system as a modular kit is therefore a logical initiative for DMG MORI, concludes Cornelius Nöb.

«

EMO SHOWCASE, MODULAR CONSTRUCTION KIT

Freely configurable, modular layout with unrestricted machine accessibility.

1. **DMU 65 monoBLOCK with Zimmer zero point clamping system** and standard automation interface
2. **AGV 50 with transport unit for machine, zero point clamping or material pallets**
Transport capacity:
 - Pallets: 500 x 500 mm (150 kg)
 - Maximum workpiece dimensions: 840 x 500 mm (600 kg)
3. **Storage rack for pallets** – free choice of number and positioning
4. **Intermediate storage** for short pallet change times
5. **Rotating setup station** – freely positionable
6. **DMG MORI MCC-LPS IV control computer**





FAMOT – the lead plant for CLX/CMX, automation excellence and digital production.



EFFICIENT XXL AUTOMATION

FOR LARGE COMPONENTS UP TO 6t

A new production plant for large, high-precision components was built as part of the modernization of the DMG MORI FAMOT plant in Pleszew, Poland. The very heart of the plant is the networking of three DMC 210 U Portal machines via a Linear Pallet Pool (LPP) 160 with pallet sizes of 1,600×1,600 mm. Waldemar Adam, Production Manager at FAMOT, talks about how DMG MORI was able to meet the demands on production capacity, component quality, flexibility and logistics with this production solution.

Mr. Adam, what were the fundamental challenges when building the new production plant?

We needed an energy-efficient, automated factory with a stable temperature for the production of high-precision components. To achieve this we had to plan for machine tools which can handle workpieces up to 40 tons.

In cooperation with the machine supplier DMG MORI, we decided on two DMU 1000 SE and three DMC 210 U machines with an LPP system. With the LPP 160, DMG MORI very quickly developed a suitable solution that fulfilled all requirements. Standardized components helped, as they could be quickly mounted on a ready-to-use rail system. The production solutions are space-saving, productive and guarantee the high demands on quality, so we

can respond flexibly and quickly to the needs of our customers. Of course, cost-effectiveness of production is also a focal point.

The LPP links three DMC 210 U Portal machines. What are the benefits of the XXL automation in day-to-day production?

Thanks to the LPP system we are able to optimize setup times. The operators can now concentrate on loading the 22 pallets at two rotary, and therefore ergonomic, setup stations and have time to operate several machines in parallel. We benefit from partially attended production and consequently reduced staffing levels at night, during the weekends and over several days at a time.

INTUITIVE CENTRAL CONTROL OF THE ENTIRE SYSTEM

Do staff need any special training to operate the LPP?

No, the intuitive LPS central control system can be operated easily after just a short training session and supports production planning and management. Of course, complete integration into production planning, work preparation and logistics is necessary.

FAMOT is the showcase plant for the DMG MORI digitization strategy. What consequences does this have for the new factory?

The plant is equipped with all our digital solutions and therefore completely integrated in our planning, production preparation, monitoring and maintenance. PLANNING SOLUTIONS, for example, is one of these solutions. DMG MORI PLANNING consists of the apps PRODUCTION PLANNING, PRODUCTION FEEDBACK and PRODUCTION COCKPIT. Planning, direct feedback from production and transparency throughout the shop floor optimize our efficiency and flexibility in day-to-day production.

«



LINEAR PALLET POOL 160

- + Workpieces up to $\varnothing 2,100$ mm and heights up to 1,400 mm
- + High transport capacity up to 8t
- + Extremely flexible pallet pool system
number of machines, setup station and pallets can be expanded freely

CENTRAL COMPUTER MCC-LPS 4

- + Efficient and intuitive **pallet control system**
- + **Overview of material stock** and planning including raw material and finished part documentation
- + **Tool management** with a display of the tools in the system and tool comparison lists
- + **Overview, planning and documentation of fixtures**



Networking of three DMC 210 U machines via a Linear Pallet Pool (LPP) with 22 pallet locations and 2 machines in μ -precision design. Two rotary, high-precision and extremely ergonomic setup stations.

The flexible production system enables cost-effective machining of large, high-precision components. We were able to increase our capacity significantly thanks to optimized utilization.

Waldemar Adam
Project Leader and Production Manager
at DMG MORI FAMOT, Pleszew

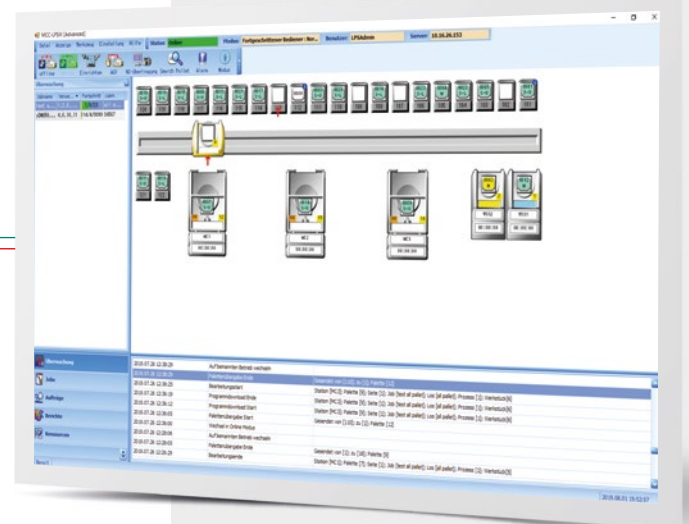

JUST IN TIME

WITH FLEXIBLE AUTOMATION FROM A BATCH SIZE OF 1

When you enter the modern buildings and factory workshops of the Zimmer Group it is difficult to imagine that the story of the corporate group began in a converted cow shed in Rheinau in 1980. At that time the brothers Günther and Martin Zimmer developed their first products for automation and handling. Today the Zimmer Group owns over 980 patents and employs 1,260 people at two production plants in Germany and it has sales centers worldwide. Consistent process optimization has been undertaken in production, where 85 machine tools from DMG MORI are in operation: eight DMC 60 H machines with three flexible production systems for up to 60 pallets have been installed since 2016.

AUTONOMOUS PRODUCTION WITH UP TO 60 PALLET POSITIONS

With ever more new products and countless patents the Zimmer Group is one of the leading manufacturers in its sector. Günther Zimmer has noticed a change in recent years: "Development cycles are getting shorter and shorter." This has led to an expansion of both the product portfolio and range of services of the Zimmer Group. Customers see the group as a technology partner that offers complete system solutions as turnkey projects.

Just in Time production – 3 production systems with up to 60 pallet positions

High competitive pressure and demands on quality call for a leading edge approach in production. That is why the Zimmer Group has worked together with DMG MORI since 2016 to install three large production systems in the handling technology division. Fastems,

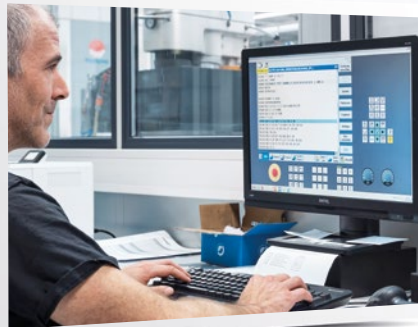

Programming of individual orders takes place on a PC in the office; production assistants load the manufacturing cells via loading stations.



Automatic production on the eight DMC 60 H machines makes us more flexible, more productive and improves our delivery capability, without the need to build up large stocks.

Günther Zimmer
 Founder and CEO of the Zimmer Group

a DMG MORI DMQP partner (DMG MORI Qualified Products), supplied the FMS-ONE with two loading stations to provide pallet storage for each system.

DMC 60 H – 5-axis simultaneous machining down to hundredths of a millimeter

All three systems are based on DMC 60 H horizontal machining centers with swivelling rotary tables for 5-axis simultaneous machining with ball screw drives. The diversity and precision of these machines make them the ideal choice for automatic production, recalls Klaus Seifried. “The DMC 60 H machines complex workpieces from aluminum and steel reliably even down to hundredths of a millimeter.”

Innovative wheel magazine for offline setup

“The three machines in the first system can machine every workpiece flexibly”, says Klaus Seifried. Each DMC 60 H has 180 tool pockets and the pallet store has 40 positions. The pallet rack of the second system is one level higher with a total of 60 pallet positions. The three DMC 60 H machines have a 5-wheel magazine for 303 tools in an extremely compact footprint. We have a different approach where this system is concerned: “Two machines produce aluminum parts, while the third is responsible for steel machining”, explains Klaus Seifried. The wheel magazine also enables setup while machining is in progress. The system installed in 2018 includes two DMC 60 H machines with the same equipment, which can machine all workpieces.

Competitive thanks to flexible 24/7 production on eight automated DMC 60 H machines

The machines can go on operating for seven days in a row with batch sizes from one to several hundred workpieces – in other words in unmanned shifts overnight or at weekends. Günther Zimmer is thinking long-term with such investments: “We have to keep the overall picture in mind and ensure that we remain competitive in future as well.” This is also true of the latest acquisition: DMG MORI will acquire another automated production center with 60 pallet positions by the end of the year. This consists of two DMC 60 H machines and a DMC 60 FD duoBLOCK for even more complex workpieces. The pallet storage system will once again be supplied by DMQP partner Fastems.

ZIMMER GROUP FACTS

- + Founded in 1980
- + Two production plants in Germany with 1,260 employees
- + Over 5,000 different products for the automation and handling technology sectors



ZIMMER Group
 Im Salmenkopf 5
 77866 Rheinau, Germany
www.zimmer-group.de



The largest of the automation systems installed to date includes three DMC 60 H machines each with a 5-wheel magazine for 303 tools.

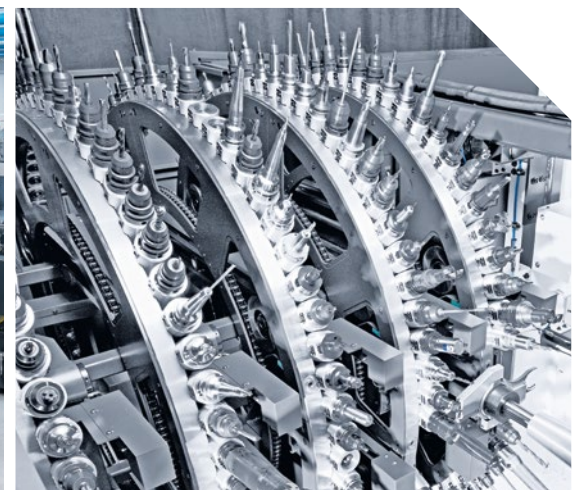

Set-up during machining with the 5-fold wheel magazine for 303 tools.

WORLD
PREMIERE
2019

THE NEW CLX 750

2,000 Nm FOR HEAVY-DUTY
TURNING OF WORKPIECES
WEIGHING UP TO 600 kg

HIGHLIGHTS

- + Workpieces with a diameter of up to **700 mm** and up to **1,290 mm long** (max. diameter 640 mm in conjunction with Y-axis*)
- + **2,000 Nm main spindle** (A2-11") with 46 kW
- + **Hollow clamping part diameter 127 mm**
- + **12-position VDI 50 turret**
- + **±80 mm Y-axis*** for off-centre machining, steady rest* up to a diameter of 430 mm
- + **Counter spindle*** ISM76 with 4,000 rpm and 360 Nm*
- + **Wide range** of exclusive DMG MORI technology cycles
- + **DMG MORI IoTconnector** as standard
- + **3D control technology** on 19" Touch-Panel, optionally with SIEMENS or FANUC

*Optional



CLX with GX6



CLX with Robo2Go

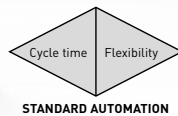

Perfect solutions:
GX Loader for fast cycle times or Robo2Go for maximum flexibility

CLX RANGE

AUTOMATION

- + **Robot or bar loader** for automation of production processes
- + **Bar loader** (draw tube internal diameter)
 - CLX 350 – ø 65 mm
 - CLX 450 – ø 80 mm
 - CLX 550 – ø 80 mm (ø 102 mm optional)
 - CLX 750 – ø 127 mm (optional)
- + **Robo2Go** for all CLX machines with SIEMENS or FANUC
 - Workpieces up to ø 170 mm
 - Load capacity 10/20/35 kg
- + **Gantry GX 6** (CLX 350 with SIEMENS)
 - Workpieces up to ø 180 x 140 mm



3D CONTROL TECHNOLOGY

- All CLX machines are available with:
- + 19" DMG MORI SLIMline Multi-Touch control with SIEMENS
 - + 19" DMG MORI SLIMline Touch control with FANUC



Robo2Go VISION

YOUR UNIVERSAL PRODUCTION ASSISTANT WITH THE CONVENIENCE OF VISION

HIGHLIGHTS

- + Quick loading and removal of raw and finished parts using a lift truck
- + No restacking due to the use of standard pallets and trolleys
- + No specific trays required
- + Quicker setup thanks to bigger workpiece capacity
- + Handling of chuck components $\varnothing 25 - 175$ mm
- + 3D camera detection of workpieces

MODULARITY - THE POWERFUL CLX MODEL SERIES FROM DMG MORI

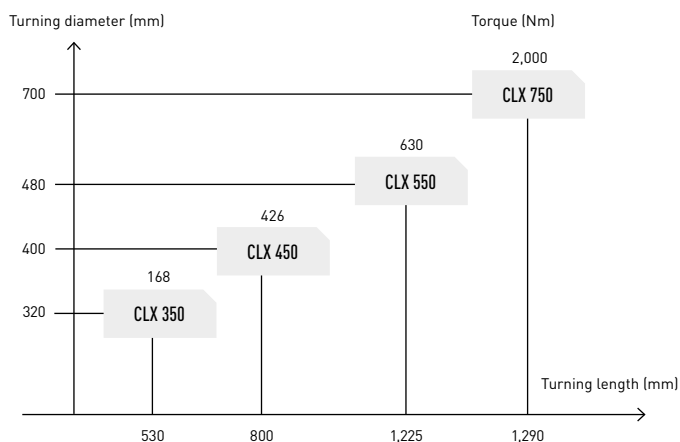

CONVERSATIONAL CONTROL WITH CELOS

HIGHLIGHTS

- + No robot programming knowledge required
- + **Multi-job function:** Different orders on one workpiece tray; **Ideal for small and medium batch sizes**
- + Creation of the process based on **predefined program blocks**
- + **Home function** for simple robot retraction and setting up of the system



Setup during machining, thanks to a separately accessible tool magazine on a CMX 70 U.



IN-HOUSE PRODUCTION ATTRACTIVE PRICING OF CLX AND CMX MACHINES

Founded in 1965 under the name Maschin-fabrik Spaichingen GmbH, today's MS Ultraschall Technologie GmbH has focused on ULTRASONIC technology since the end of the 1980s, a sector in which it is now one of the leading suppliers. More specifically MS Ultraschall Technologie develops machines for ULTRASONIC welding of plastics and textiles for customers in the automotive, textile and medical technology industries. MS Ultraschall Technologie ensures the high quality demanded by its customers using a wide range of different machines from DMG MORI installed on its shopfloor. The team has been producing workpieces in-house for some time now – on the productive and attractively priced CLX and CMX U machines.

"Manufacturing our products ourselves means we have better control over quality and can work far more flexibly when it comes to meeting deadlines", is how Sascha Medenica,

Production Manager at MS Ultraschall Technologie, explains the decision to manufacture more products in-house. Vertical integration today is up to 90 percent. "The services we offer range from the development and manufacture of our often customer-specific products through the entire production to servicing." Around 400 employees at the location in Spaichingen alone work to ensure all processes run smoothly.

The right DMG MORI machine for every workpiece

MS Ultraschall Technologie uses very different DMG MORI models in its production depending on the component requirements. "We machine workpieces that need subsequent polishing on a DMU 60 eVo *linear*, because it already produces extremely high-quality surfaces. This reduces polishing time", explains Sascha Medenica. Complex turn-mill parts can be produced very efficiently on three CTX beta TC machines.

Due to the productive and attractively priced CLX and CMX machines, we now manufacture more than 90% of our products in-house.

Sascha Medenica
Production Manager
at MS Ultraschall Technologie GmbH

6-sided complete machining with the CLX 450

A CMX 50 U, four CMX 70 U machines and a CLX 450 have been installed since 2018 due to the intention of MS Ultraschall to machine even simple workpieces itself. "In this case it is not only the technical advantages of the machines that count, but also their attractive purchase price which makes it feasible to produce parts ourselves that we formerly purchased", says Sascha Medenica. A universal turning machine with ± 60 mm Y-axis travel and driven tooling, the CLX 450 is also capable of milling operations on more



A CMX 50 U and four CMX 70 U machines have been installed since 2018, among others.



The 5-axis CMX U machines are the versatile all-rounders in production.

Complex workpieces are an integral part of the range of components at MS Ultraschall Technologie.



complex workpieces. It has a highly dynamic 25.5 kW spindle drive, 426 Nm torque and a maximum speed of up to 4,000 rpm. A rigid cast iron bed optimizes vibration characteristics, while high thermal stability and linear scales guarantee the required precision in 6-sided complete machining. The machine's compact 6.8 m² footprint, despite a turning diameter of \varnothing 400 mm and a distance between centers of 800 mm, is also of benefit to MS Ultraschall Technologie.

CLX – Y-AXIS AND COUNTER-SPINDLE FOR COMPLEX WORKPIECES

Productive 5-axis milling on CMX U machines

Like the CLX 450, the 5-axis CMX U machines are also designed for complete machining. "We need this capability to remain sufficiently productive", remarks Sascha Medenica. The CMX 70 U in particular has proved a versatile all-rounder. Its B-axis has a swivel range of -10° to 95° . With a diameter of 800×620 mm,

the table is designed for heavy components weighing up to 350 kg. An FEM-optimized design and roller guideways ensure maximum rigidity and stable machining, while the linear scales that are part of the standard equipment of all CLX and CMX machines guarantee high precision. In addition all CMX V and CMX U machines will in future be available with the option of an inlineMASTER spindle including 36-month warranty (see page 46/47).

The good accessibility of the CMX U machines makes work easier for the operators. The tool magazine of the two latest models in particular, which offers an optional 60 pockets and can be accessed through its own door, is what makes setup during machining possible. According to Sascha Medenica another new ergonomic feature of the two CMX 70 U machines is the 3D control: "The 19" multi-touch screen enables intuitive and user-friendly operation." All CMX V und CMX U machines come equipped with this panel in their standard versions – available with control systems from SIEMENS or HEIDENHAIN. From EMO onwards, all CLX, CMX V and CMX U machines will also be equipped with the DMG MORI IoTconnector as standard.

MS ULTRASCHALL TECHNOLOGIE FACTS

- + Founded in Spaichingen in 1965
- + 400 employees
- + Development and construction of machines for ULTRASONIC welding
- + Customers from the automotive, textile and medical technology industries



MS Ultraschall Technologie GmbH
Karlstraße 8 – 20
78549 Spaichingen, Germany
www.ms-ultraschall.de



NEW: inlineMASTER SPINDLE

FOR THE CMX V AND CMX U WITH 36-MONTH WARRANTY

HIGHLIGHTS

- + Proven DMG MORI quality with MASTER spindles
- + 12,000 rpm inlineMASTER spindle with 83 Nm and 13 kW (optional)
- + 15,000 rpm inlineMASTER spindle with 121 Nm and 20 kW (optional)
- + 36-month warranty on all MASTER spindles with unlimited spindle hours
- + Direct delivery from EMO 2019 onwards

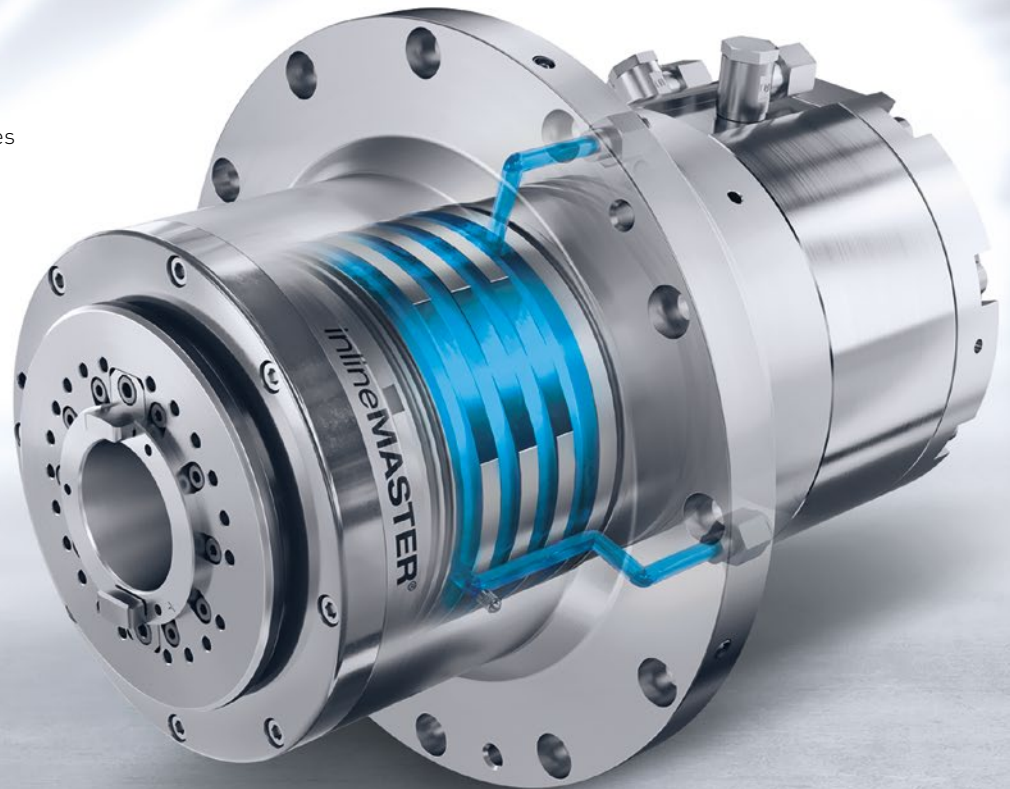

36 MONTHS

Warranty for
all MASTER spindles
with unlimited
spindle hours

PH 150

PALLET HANDLING PH 150

OPERATION DIRECTLY FROM THE MACHINE CONTROL

HIGHLIGHTS

- + Available for all CMX V and CMX U machines
- + Operation directly via the machine control, no additional external control for automation
- + Max. load capacity 150 kg (250 kg*)
- + One handling unit for all pallet sizes:
10 pallets 320 × 320 mm, 6 pallets* 400 × 400 mm,
4 pallets 500 × 500 mm
- + EROWA workholding system as standard, optionally SCHUNK
- + Maximum clamping force of up to 112 kN with turbo function and SCHUNK VERO-S chuck
- + Reduced downtime
- + Highly repeatable clamping accuracy of the pallets; < 0.002 mm with EROWA UPC-P chuck

*optional

PH 150
COMPLETE
SOLUTION
FROM A SINGLE
SOURCE!



CMX V & CMX U
READY FOR
AUTOMATION
with 60-pocket tool
magazine*

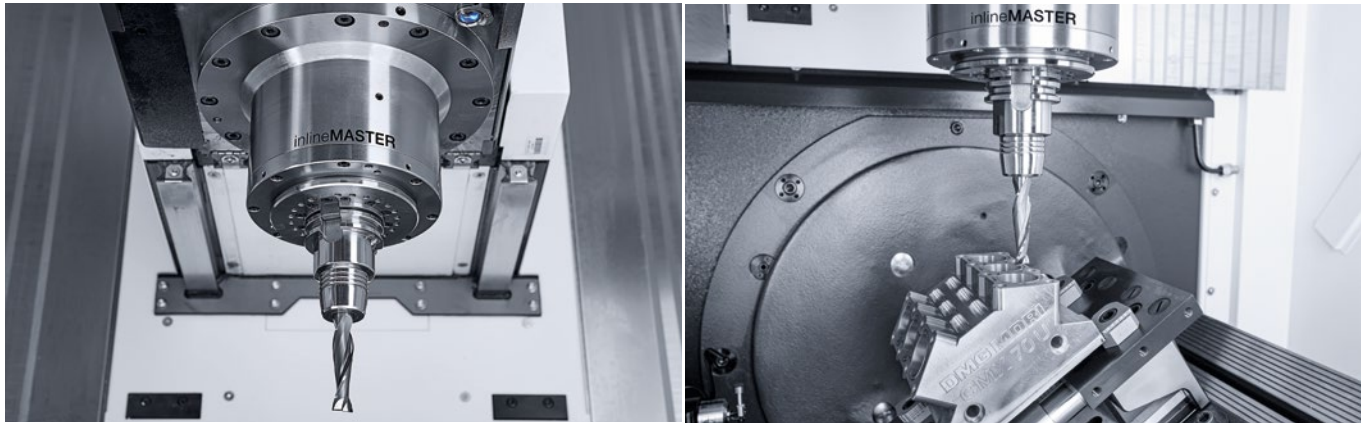

inlineMASTER SPINDLE

- + Better cutting performance due to **53% higher spindle power** and **45% higher torque** with the 15,000 rpm inlineMASTER (20 kW, 121 Nm at 40% DC)
- + **25% faster spindle speed** for improved surface quality
- + **BIG PLUS® interface** for longer tool service life: Elimination of Z-axis movement at high rotational speeds due to face contact
- + **Oil/air lubrication** of the spindle bearing and improved ribbed structure for long service life
- + **Liquid cooling** for optimum thermal stability

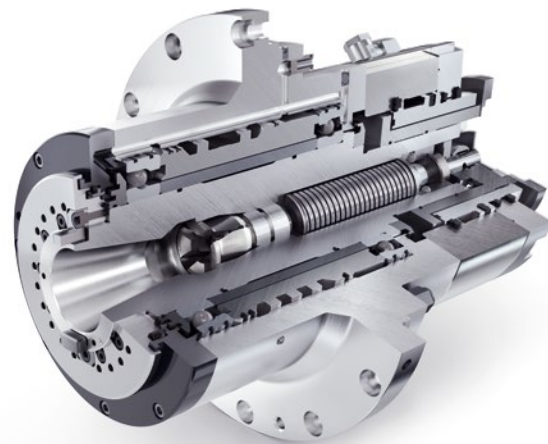

WH CELL

MODULAR WORKPIECE AUTOMATION FOR THE CMX V AND CMX U

HIGHLIGHTS

- + **Modular automation system** for workpieces up to 15 kg
- + **Recirculating or drawer workpiece storage:**
max. workpiece size of up to 300 x 300 x 220 mm
max. load capacity of 250 kg
- + **KUKA industrial robot with different gripper variants from SCHUNK:** Single or double gripper including customer-specific gripper jaws
- + **Expansions (optional):** SPC drawer, NOK chute, blow-off station, turnover unit and much more



Availability	CMX 600 V	CMX 800 V	CMX 1100 V	CMX 50 U	CMX 70 U
WH 6 CELL	•	•	•	•	•
WH 8 CELL	◦	◦	–	•	–
WH 15 CELL	•	•	•	•	•

• Available – not available
◦ WH 8 CELL: On request only



NTX & CTX TC SERIES

6-SIDED TURN & MILL COMPLETE MACHINING

Exclusive Technology Cycle Turning and Turn & Mill

3D quickSET – TURNING

- + Measurement and correction of the position of turning and Pivot axes (C4/C3/B)
- + Sag compensation possible
- + Can be used in combination with standard probes from customers (recommended Renishaw, Blum)



CUSTOMER BENEFIT

- + Reliable re-calibration of the machine before a highly precise processing
- + Continuous documentation of machine accuracy
- + No rejected parts due to unknown Geometric-deviations



Find out more about the
Technology Cycles at:
techcycles.dmgmori.com

NTX 1000 2nd GENERATION

- + 5-axis simultaneous machining of complex workpieces with **Direct Drive (DDM technology) on the B axis**
- + Up to **10 driven tools on the BMT turret** (optional) rated at up to 10,000 rpm
- + Large working area for **workpieces up to 800 mm in length and 430 mm in diameter**, chuck size up to 200 mm in diameter
- + **CELOS with MAPPS on FANUC or CELOS with SIEMENS**

NTX 2000 / 2500 / 3000 2nd GENERATION

- + 5-axis simultaneous machining of complex workpieces with **Direct Drive (DDM technology) on the B axis**
- + **compactMASTER** – the world's shortest tool spindle in its class (350 mm), ensures a wide machining envelope to increase productivity
- + Wide range of machining area with the **X-axis stroke of 675 mm** (-125 – +550 mm) and the **Y-axis 300 mm** (±150 mm)
- + **CELOS with MAPPS on FANUC or CELOS with SIEMENS**



NTX 1000 with IMTR
(In Machine Travelling Robot)



CTX gamma 2000 TC with GX 60 T

CTX beta & gamma TC

- + **100 % TURNING:** Up to 700 mm turning diameter and up to 4,000 Nm torque on the main spindle
- + **100 % MILLING:** compactMASTER – up to 20,000 rpm with 120 Nm, or 12,000 rpm with 220 Nm (gamma TC only)
- + **100 % TOOLS:** Up to 180 tools for highest flexibility
- + **CELOS with SIEMENS**

TURN & MILL PORTFOLIO

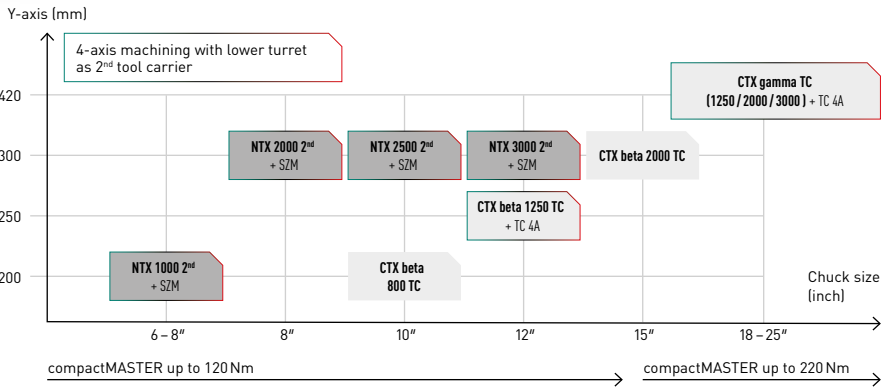

MANUFACTURING CAPACITY DOUBLED

GE Avio Aero, a subsidiary of GE Aviation, is involved in the development, manufacture and maintenance of components and systems for civil and military aviation. The company provides its customers with innovative solutions in order to react quickly to the continuous changes that take place in the industry: Additive manufacturing, rapid prototyping and technologies for manufacturing gearboxes, turbines and combustion chambers. The company headquarters is in Rivalta di Torino, Italy. In the factory there, GE Avio Aero has installed a production line consisting of four DMU 80 FD duoBLOCKs for manufacturing turbine disks and has more than doubled production capacity.

“The GE Avio Aero factory in Rivalta di Torino is a specialist in the design, manufacturing and installation of gearboxes and low-pressure

turbines for civil and military aircraft engines and industrial and maritime applications”, says Mauro Canola, manufacturing engineer at the Piedmont site. One focus is the production of turbine disks for CFM international’s

These special nickel alloys are highly heat resistant and corrosion resistant. Mauro Canola explains: “As they are extremely tough, they are difficult to machine and a high level of technological expertise is required to meet the high quality standards.”

PLANNING, MAINTENANCE AND MONITORING WITH CELOS

Customer-specific automation with four DMU 80 FD duoBLOCKs

The turbine disk production capacity for SAFRAN Aircraft Engines was 1,500 disks per year. When the customer asked for an additional 1,700 turbine disks a year, the manufacturing capacity had to be increased. Since GE Avio Aero has worked successfully with milling-turning machines from DMG MORI for a considerable time, the logical step was to make further investments in this technology. Due to the high quantities, automated production was suggested. The

LEAP engine, a joint venture of SAFRAN Aircraft Engines and General Electric. The outer diameters are between 400 and 1,000 mm. The materials are Inconel 718 and Renè 88.



Customer-specific automation:
Four automated DMU 80 FD duoBLOCKs linked to a pallet storage system.



Quality control: Visual inspection of a turbine disk made from Inconel 718.



Setup station for the production line with the four DMU 80 FD duoBLOCKs.

Source: Tecnologie Meccaniche, issue June 2019.

result is a manufacturing line consisting of four DMU 80 FD duoBLOCK machines and a pallet storage system that can be extended to six machines in total. It must be emphasized that this is a customized solution. The pallets are transferred directly from the storage system to the working area.

Close cooperation with the DMG MORI Aerospace Excellence Center

With many years of experience and a high degree of expertise, the DMG MORI Aerospace Excellence Center is in a position to implement individual and optimum manufacturing solutions for aeronautical engineering customers. In the case of GE Avio Aero, the experts there were involved in the project at an early stage in order to implement the special requirements. This included designing the technology with fixtures, machining strategies, system automation and tool selection. "We required a large number of tool stations for using sister tools," adds Mauro Canola. The innovative wheel magazine with 183 tool pockets fitted to the DMU 80 FD duoBLOCK makes tool replacement during machining possible.

CELOS for digitized planning, control and monitoring of production

DMG MORI also supported GE Avio Aero on the path to intelligent and networked production. "Thanks to CELOS we were able to plan, control and monitor production the entire

production line," says Mauro Canola, describing the new developments in digitization. In conjunction with MT Connect, among other apps they were able to use the DMG MORI Messenger, Service Agent and NETservice software solutions. These communicate with GE Avio Aero's IT systems.

All participants benefited from the close cooperation between GE Avio Aero and the DMG MORI Aerospace Excellence Center, as Mauro Canola states: "Whilst we were informing DMG MORI about the standards and specifications for the two disk types, we got to know the potential of the new manufacturing cell at the same time." GE Avio Aero shared a great deal with DMG MORI and both partners benefited from the increase in expertise. "The collaboration depends on information, exchange of ideas and technological innovations."

"Thanks to DMG MORI, we manufacture turbine disks with an error rate of almost zero."

Mauro Canola was impressed by the intensive development work with DMG MORI. That is unsurprising, as production rate was increased significantly: "After having originally planned for 20 turbine disks per week, we now manufacture 38 disks – and with an error rate of almost zero."

GE AVIO AERO FACTS

- + Founded in 1908
- + Headquarters in Rivalta di Torino
- + 4,600 employees
- + Manufacturing of components and systems for civil and military aviation



GE Avio Aero
Via I Maggio, 99
10040 Rivalta di Torino, Italy
www.avioaero.com





DMC 125 FD duoBLOCK

COMPLETE PRODUCTION IN A SINGLE SETUP

HIGHLIGHTS

- + Milling and turning in a single setup with Direct Drive table and speeds up to 500 rpm
- + High surface quality thanks to integrated grinding technology
- + Maximum component accuracy due to water-cooled axis drives
- + SGS: Spindle Growth Sensor for compensation of spindle growth
- + Fast, extremely compact rotary pallet changer in the standard version for setup during machining
- + powerMASTER 1000 motor spindle with 1,000 rpm and 77 kW
- + 5X torqueMASTER with 1,800 rpm and 52 kW

ERGONOMIC LOADING OF TOOLS WEIGHING UP TO 30 KG

Turbines, structural components and other products from GKN Aerospace are on aircraft flying more than 100,000 times a day. All the leading engine manufacturers trust in solutions provided by the company, whose history dates back to the 18th century. 2,300 of the company's 17,000 global employees work at GKN Aerospace Engine Systems in the Swedish city of Trollhättan, where they are responsible for the development and manufacture of turbines. The demanding production is carried out on nearly 30 DMG MORI machining centers, among others. Since 2018 GKN has expanded its

production to include four DMC 125 FD duoBLOCK machines, which are used for machining an engine for Pratt & Whitney. A fifth machine is to be installed at the end of 2019. DMG MORI worked closely with GKN to develop an ergonomic loading station for the wheel magazine of the DMC 125 FD duoBLOCK that would make loading of the tool magazine with the milling cutters and drills weighing up to 16 kg (max. 30 kg possible) used at GKN more user friendly. The solution is now also available for other users as an option.



l. to r.: Kenneth Lööf, Technological Coordinator Purchasing, GKN Aerospace Engine Systems, Sandra Broberg, project leader and Björn Nilsson, machine operator.

Accounting for 39 percent of group turnover, GKN Aerospace Engine Systems is a supporting pillar of the organisation, which boasts 51 production sites in 14 countries. The boom in the aerospace sector plus the fact that all leading engine manufacturers order products from GKN has put the company on a sound economic footing. "Consistent investment in both the training of our employees and in production technology means we can keep pace with the demanding order situation", explains Joakim Wilson, Manager Machine Maintenance & Procurement at GKN Aerospace Engine Systems.

SOLUTION-ORIENTED DEVELOPMENT FOR A HIGH LEVEL OF USER FRIENDLINESS

Individual special solutions for enhanced ergonomics from DMG MORI

Ergonomic operation was a decisive factor for the purchase of five extensively equipped DMC 125 FD duoBLOCK machines. Two of these models had already been put into operation two years previously, but loading of the wheel magazine with the extremely heavy tools had proved very strenuous. Kenneth Lööf saw a need for action with the latest order: "Internal studies have shown the acceptable level of long-term physical exertion. Loading of tools weighing up to 16 kg as is the case in our company no longer met the requirements." Depending on the setup there can be up to 50 tool changes one after the other. GKN Aerospace Engine Systems asked DMG MORI to find a solution that would reduce the physical effort required.

Setting up sets of eight tools at a time with maximum ergonomics

The experience they had made to date meant that Sandra Broberg, project manager at GKN Aerospace Engine Systems, and her colleagues knew exactly what was required of an alternative solution: "We needed an ergonomic solution that would be easy for all our male and female employees to use." DMG MORI worked together with GKN Aerospace Engine Systems and developed a loading station that enabled more ergonomic and easier loading and unloading. "The station has eight horizontally arranged tool pockets and its height can be adjusted to that of the respective operator", explains Kenneth Lööf. This has created the shortest possible distance from the tool trolley to the magazine. Once all eight tools are in place, the machine automatically exchanges the tools into the rotary magazine.

75 percent shorter setup times

Björn Nilsson, who works daily with the new loading station, is pleased with this improvement: "The ergonomic handling system ensures physical strain is kept to a minimum, especially during peak times." Joakim Wilson is also well satisfied with the solution-oriented development for this special requirement: "We are pleased with all the effort GKN and DMG MORI put in to finding this solution. DMG MORI understood the daily work of our operators and helped us to arrange it in a more ergonomic way." This led to the development of a more ergonomic and efficient solution. Björn Nilsson points out another positive side effect: "Loading times have been reduced by up to 75 percent."

From special solution to new option

DMG MORI recognized the added value of the loading station it had developed for GKN Aerospace Engine Systems and has now included it as an additional option, so other customers can also benefit from this solution.

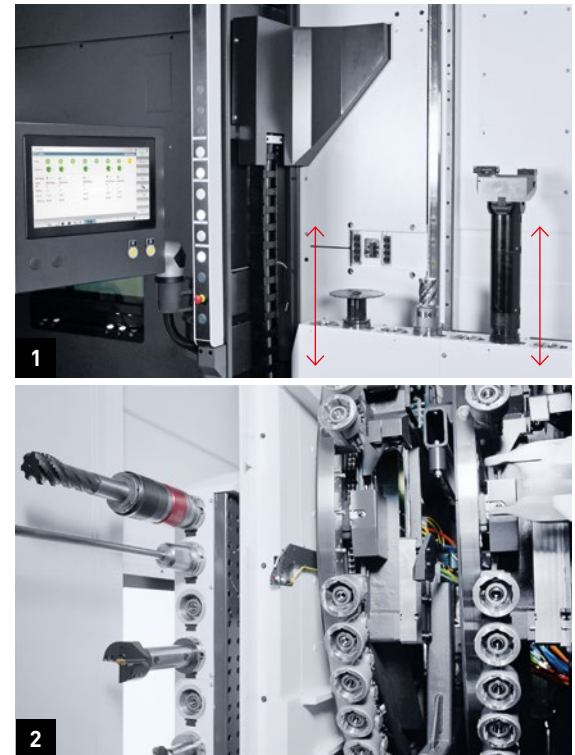

1. Perfect ergonomics: Height-adjustable tool loading station for setting up sets of 8 tools each weighing 30 kg incl. tool identification.
2. Automatic exchanging of the tools from the loading station to the wheel magazine.

GKN AEROSPACE FACTS

- + 2,300 employees at the headquarters of GKN Aerospace Engine Systems in Trollhättan
- + Development and manufacture of turbines
- + Supplier to all leading engine manufacturers



GKN Aerospace Engine Systems
Flygmotorvägen 1
461 38 Trollhättan, Sweden
www.gknaerospace.com



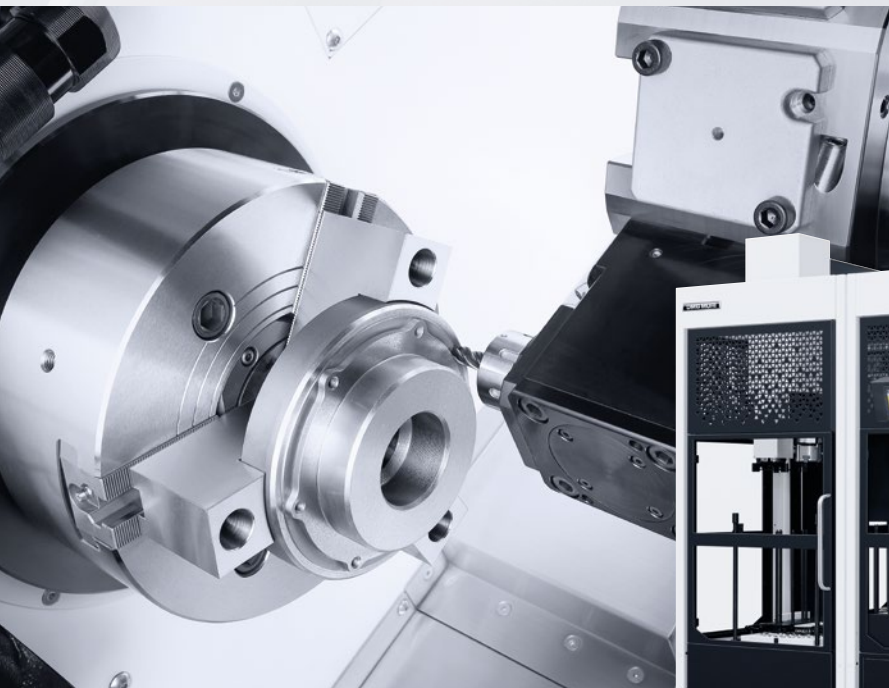

BMT turret with max. 12,000 rpm and max. 15,9 Nm for machining with driven tools.



ALX 2500 with a GX15 gantry loader for workpieces up to $\varnothing 200 \times 150$ mm

ALX-COMPACT TURNING MACHINES:

AUTOMATED SERIES PRODUCTION

ALX-SERIES HIGHLIGHTS

- + **36 expansion options** to meet all production requirements
- + **4 turning lengths:** 300, 500, 1,000 und 2,000 mm (distance between centres)
- + **turnMASTER Spindles** (Direct Drive) with 0.4 μ m concentricity and **36-month warranty** with unlimited hours
- + **Box ways** (X-axis) and **linear guideways** (Y-/Z-axis) for enhanced damping properties and dynamic rigidity
- + **Latest 3D control technology:** 12.1" COMPACTline with MAPPS Pro (300 & 500), 15" SLIMline with MAPPS (1000 & 2000)
- + **11 Technology Cycles** for expanded machining options, e.g. eccentric machining, multi-threading cycle, etc.
- + Energy-saving function **DMG MORI GREENmode**



HYDRAULIC FITTING

Dimensions: $\varnothing 30 \times 35$ mm
Material: S45C



AUTOMOTIVE CASING

Dimensions: 100 \times 80 \times 50 mm
Material: ADC



MACHINE BUILDING SPINDLE

Dimensions: $\varnothing 230 \times 400$ mm
Material: SCM



ENERGY

BORE CASING

Dimensions: $\varnothing 200 \times 1.000$ mm
Material: 13Cr

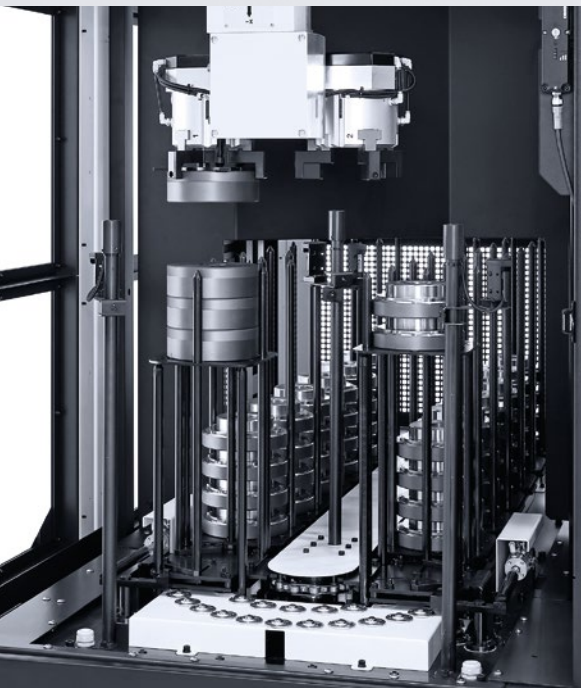

Storage for up to 20 pallets with a maximum weight of 75 kg and up to 26 to a maximum of 35 kg per station.

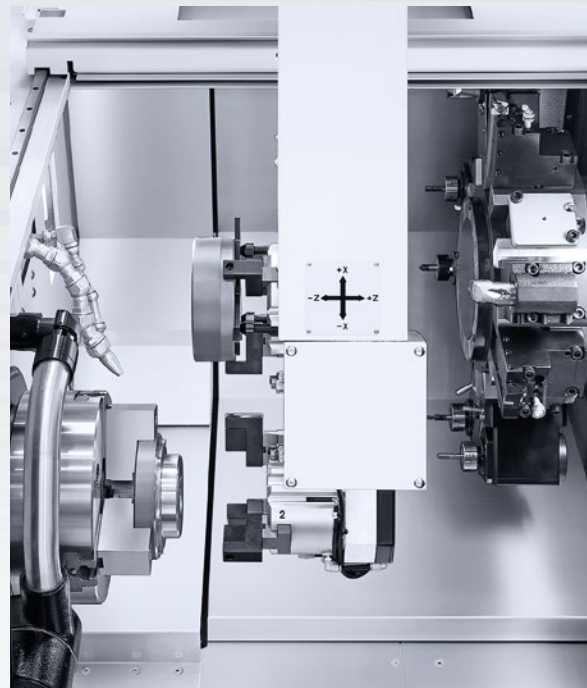

Loading arm with integrated double gripper for workpieces up to ø200 mm, 150 mm in length and 15 kg (per hand).



Inspection station for in-process measurement during production.

ALX – SUCCESSOR OF THE CL SERIES, OF WHICH 10,000 HAVE BEEN INSTALLED



Footprint comparable to the CL 1500/CL 2000 (300 turning version)

35 EXPANSION OPTIONS WITH 4 TURNING LENGTHS

BMT-turret [MC, Y, SY]
with 12,000 rpm / 5.5 kW / 15.9 Nm (25% DC)



Spindle	Chuck size	Turning length			
		300	500	1000	2000
ALX 1500	6"	•	•	•	•
ALX 2000	8"	•	•	•	•
ALX 2500	10"	•	•	•	•
without tailstock	T		T, MC, Y, SY		T, MC, Y

• available, - not available, T = turning, MC = powered tools, Y = Y-axis, S = counter spindle

Temperature concept

- + Integrated coolant circulation in the machine bed for enhanced thermal stability (300, 500 and 1000 versions)
- + Integrated oil cooling of the turning spindle and BMT turret

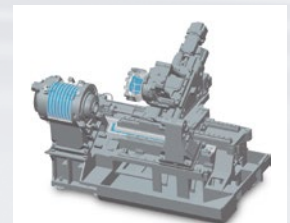

Accessibility and maintenance

- Ideal for automation, direct access from the front for daily maintenance, e.g.
- + Tank for oil lubricant and waste oil container
 - + Chip conveyor with discharge to the right or left (optional)



turnMASTER spindles

(Direct Drive) with **36-month warranty** with unlimited hours



turnMASTER spindles (10% DC)*			
	Chuck size	Rotational speed	Power/Torque
ALX 1500	6"	6,000 rpm	15 kW / 179 Nm
ALX 2000	8"	4,500 rpm	22 kW / 253 Nm
ALX 2500	10"	3,500 rpm	30 kW / 796 Nm

* Counter spindle 6": 7,000 rpm, 11 kW, 78 Nm (25% DC)

100 × CTV

FLEXIBILITY IN HIGH-VOLUME PRODUCTION AT VW IN WOLFSBURG



l. to r.: Ralph Mässelhäuser (DMG MORI), Torsten Giessler (VW, Planning Components Chassis), Matthias Schrader (VW, Head of Planning Components Chassis) and Dr. Peter Blümel (VW, Planning Components Chassis) in front of the new CTV 250 DF.

Car manufacturing places the highest demands on accuracy and productivity in mass production. Manufacturers are required to continuously optimize their processes in order to produce sophisticated workpieces efficiently. A good example of this is the production of drive shafts at the VW plant in Wolfsburg. DMG MORI installed the first vertical turning machine in the plant, a CTV 160, as far back as 2009. Short cycle times, optimum chip flow and high precision were so convincing that other models have been added over the years, such as the CTV 250 and CTV 250 DF. The latest purchases, six CTV 250 DF 3rd Generation machines, include the 100th vertical turning machine in the CTV series that DMG MORI has delivered to VW.

The CTV 250 DF 3rd Generation is designed for machining materials in both their soft and hardened states. An optional mini turret with its eight additional tool stations ensures enhanced machining possibilities. There is

also space-saving integrated portal automation for virtually unmanned operation. It consists of two accumulating conveyors, a portal gripper, a shuttle and optional turning station for 6-sided complete machining. This system enables angular positioning and alignment, offering optimum accessibility to the pick-up station and turntable.

COOPERATION BETWEEN VW AND DMG MORI

Cooperation between VW and DMG MORI

Optimal dynamic and thermal stiffness of the CTV 3rd generation. The optimization of production processes requires close cooperation between user and machine supplier. In the case of the latest CTV machines, VW

has cooperated very closely with DMG MORI within the FAST partnership in order to obtain an optimum manufacturing solution. With the FAST program, VW aims to optimize and intensify interactions between the Volkswagen group and its suppliers.

The resulting CTV 250 DF 3rd Generation is specially tailored to the requirements of component production in Wolfsburg. "In particular further enhancement of dynamics and thermal rigidity for even higher productivity was a key development goal", explain Dr. Peter Blümel and Torsten Giessler from the Planning Department of Components Chassis Wolfsburg. "Another goal of the joint development was greater flexibility of the CTV 250 DF 3rd Generation", Head of Planning Matthias Schrader goes on to tell us. DMG MORI was able to realize these requirements in a decisive manner.

DMG MORI Technology Cycles Grinding and gearSKIVING 2.0

DMG MORI integrated its own technology cycles, such as Grinding and gearSKIVING, to achieve maximum machining diversity. This does away with the need for special machines and workpieces that had formerly been produced on several machines can now be manufactured in a single setup. This reduced overall cycle times drastically as well as increasing the accuracy of the finished parts. The CTV 250 DF 3rd Generation meets the high demanding accuracy requirements thanks to its rigid and thermally stable construction. An optional measuring system provides in-process gauging for consistent machining quality.

30 % energy saving

The design of the machine had a significant impact on the development of the CTV 250 DF 3rd Generation. A new loading concept enables different installation options for users and possibilities with regards to linking machines for component production. Another topic of vital importance in large-volume production,



5-axis milling of an inner ball race on the CTV 250 DF.

where machines operate around the clock, is energy efficiency. The CTV 250 DF 3rd Generation performs extremely well in respect of both electricity and air consumption. DMG MORI has achieved up to 30 percent energy savings through energy efficiency measures.

CELOS for end-to-end integration in the production process

As far as the control is concerned the CTV 250 DF 3rd Generation, like all high-tech machines from DMG MORI, is equipped with CELOS. This means that, in line with Industry 4.0, the vertical turning machine can be integrated into the entire end-to-end production process.

«

VOLKSWAGEN AG FACTS

- + Founded in 1937
- + Over 650,000 employees worldwide
- + Headquarters in Wolfsburg with over 55,000 employees
- + Production in Wolfsburg includes chassis and plastics technology



Volkswagen AG
 Berliner Ring 2
 38440 Wolfsburg, Germany
www.volkswagen.de



CTV 250 DF

THE VERTICAL TURNING AND MILLING CENTER FOR THE MACHINING OF CONSTANT VELOCITY JOINTS

HIGHLIGHTS

- + **Turn-mill swivelling tool carrier with Direct Drive** and a swivel range of +90/-30°
- + **Up to two milling spindles**
 HSK-C63-F80, 6,000 rpm, 14.5 kW, 46 Nm (40 % DC)
- + Capto C5 holder for **multiple tools with up to 4 cutting edges**
- + **Additional turret with 8 tool stations** (optional)
- + **DMG MORI Technology Cycle gearSKIVING 2.0**
 gearSKIVING for straight and helical gears

VL JOURNAL (CF53)

1. Machining of the ball races
 ø18 mm, 30 sec. cycle time
2. gearSKIVING of the teeth
 Straight tooth module 0.9
 20 sec. cycle time



Thanks to the integration of technology cycles such as gearSKIVING 2.0 DMG MORI achieves maximum machining capability on the CTV 250 DF.



You will find more information on the CTV 250 DF 3rd Generation ctv.dmgmori.com

RUIGU Technology manufactures bearing cages in different sizes.

100% INCREASE IN PRODUCTIVITY WITH THE DMC 210 U



RUIGU production manager Mr. Chen in front of the DMC 210 U on which oversize bearing cages are manufactured.

RUIGU Technology, which was established in 2006, focuses on the development and production of a wide variety of medium-size, large and oversize bearing cages and steering components. It is a partner to major brands in the industry such as Schaeffler, TIMKEN, AB SKF and other global manufacturers with this range of products. The partnership with these companies clearly shows that RUIGU Technology provides excellent manufacturing services. This has resulted in awards such as “Excellent Supplier” and “Best Supplier” from Schaeffler and TIMKEN operating in Greater China. The high quality production is supported by four DMU 50 and two DMC 210 U 5-axis machining centers, among other equipment.

RUIGU Technology has now become one of the world’s most important players in the manufacture and sale of bearing cages, an area which is expanding dynamically. “RUIGU Technology wants to be the best in

the world.” Explains the president of RUIGU Technology, Mr. Jiang: “Without the support of cutting-edge machine tools, this goal can never be achieved. I am very happy that we have finally found the perfect machine tools in high-end systems from DMG MORI.”

OPTIMUM MACHINING PRECISION FOR COMPLEX WORKPIECES

DMG MORI products are characterized by maximum precision, efficiency and stability At RUIGU Technology they know that the growth of a company is closely associated with key factors such as the continuous development of new, better products with greater

precision, better quality, simpler structures and lower prices. This is the only way in which customer requirements can be fulfilled in the long term. The company therefore expects machine tools to operate with maximum precision, maximum efficiency and maximum stability. These are precisely the characteristics that products from DMG MORI have.

Tripling of capacity with DMG MORI machines

“At present, RUIGU Technology produces up to 300,000 bearing and steering components per annum. This number will increase to almost one million by 2020 due to expansion of the manufacturing capacity.”

Mr. Jiang says: “There is no question that the machines from DMG MORI give RUIGU Technology significant advantages. We are also very impressed with the professional and totally committed service that DMG MORI provides. If necessary, we receive help from



*We can rely on
DMG MORI completely.*

Yongjun Jiang
President
of RUIGU Technology

DMG MORI within 24 hours. Due to the outstanding cooperation, we will certainly be investing in further advanced machine tools from DMG MORI."

5-axis machines from DMG MORI guarantee the manufacture of high-precision and complex workpieces. "DMG MORI provides exactly the advanced machine tools with optimum precision and excellent stability that can cope with any task, even under very difficult conditions." Mr. Jiang gushes with praise for DMG MORI machining centers: "Our high-precision and complex structures, which are difficult to manufacture, are exclusively made on DMG MORI machines." DMG MORI machining centers have gained the trust of RUIGU Technology because of their outstanding performance.

Over the course of time, RUIGU Technology has acquired four DMU 50s and two DMC 210 Us for 5-axis machining. They now have a total of 19 machines from DMG MORI. "Our plan is to replace all of the other machines in our plant with machines from DMG MORI in the future." It couldn't be clearer that Mr. Jiang has put all of his trust in DMG MORI.

30% productivity increase due to DMG MORI 5-axis machines

The production manager at RUIGU Technology, Mr. Chen, points out that the machines from DMG MORI do not just guarantee high quality but have also increased manufacturing efficiency by an average of 30 percent. Mr. Jiang and Mr. Chen mention several times that the DMG MORI 5-axis machining center DMC 210 U that was introduced in 2017 "has even doubled the productivity of over-size bearing cages!" Mr. Chen adds: "Since it was installed, the machining center has been running flat out without interruption – a truly marvellous contribution."

In view of rapid development, at RUIGU Technology they are concentrating not on product quality alone but also on productivity. The machines from DMG MORI ensure that RUIGU Technology can continue to expand

continuously. Mr. Jiang adds proudly: "The products that are supplied by the RUIGU Technology plant qualify as real exceptions because of the fantastic performance of the DMG MORI machines: All new developments (PPAP products) can be transferred directly to mass production, which is certainly not usually the case!"

Mr. Jiang does not have to think for very long to summarize his opinion: "We can rely on DMG MORI completely."



Four DMU 50 machines from DMG MORI in the Dalian RUIGU plant in China.

DALIAN RUIGU TECHNOLOGY FACTS

- + Founded in 2006
- + Development and manufacture of bearing cages and steering components
- + Supplier to major players in the industry such as Schaeffler, TIMKEN and AB SF



RGTECH

Dalian RUIGU Technology Co. Ltd.
No.1, Xinggong Avenue, Wafangdian
Liaoning 116300, China
www.dlruigu.cn



5-AXIS MACHINING AROUND THE CLOCK



For us, customer orientation means fast delivery and at the same time perfect manufacturing quality. That's exactly why the two DMC 80 U duoBLOCKs are the ideal machines.

Wolfgang Hack
Managing Director
HACK Formenbau GmbH

Hack Formenbau was founded in 1956 in Kirchheim unter Teck.

More than 60 years experience and innovative processes make Hack Formenbau GmbH one of the leading suppliers of complex and at the same time absolutely precise moulds for plastic injection moulding. The portfolio includes single component and multi-component moulds as well as multi-cavity moulds and stack moulds. With a fully equipped production and their own injection moulding systems for mould proving, the mould making specialists based in Kirchheim unter Teck supply customers from very different industries – including medical engineering, cosmetics and hygiene industry, but also the automotive industry. With regard to chip removal, Hack Formenbau has been relying on machine tool technology from DMG MORI for many years. The latest investment saw two older DMC 80 U duoBLOCK machines replaced by the successor models of the currently fourth generation – including automation solutions with rotary storage units for twelve pallets each.

Hack Formenbau represents complex and precise injection moulds, whose development “requires a high degree of innovative power”, says Wolfgang Hack. The Managing Director took over the company from his father in 1978. His son Gunnar Hack, also Managing

5-AXIS MILLING WITH HIGH DYNAMICS AND PERFORMANCE

Director, is already continuing the success story: “Above all, we are interested in large multi-cavity moulds with an output of at least one million parts per year.” Often, it is significantly more plastic goods originating from the 32-, 48- or even 64-fold moulds. “This is why we supply a very wide range of industries.” It is this positive business development

I can optimize my process perfectly via simple windows and without expert knowledge of the control system.



that allows Wolfgang and Gunnar Hack to be optimistic for the future. The in-house training of precision machinists is to further support the ongoing employee growth, and the expansion of production capacities is also planned in the long-term.

DMG MORI machining centers for precise and reliable 5-axis machining

The focus is on customer orientation for all orders, says Wolfgang Hack: "This means: fast delivery with at the same time perfect manufacturing quality." Experienced and

competent specialist staff are the basis for this, using innovative technologies and well thought-out processes. At Hack, the process begins with the development including CAD design and CAM programming. In production, the experts cover all common machining processes, from milling and circular and profile grinding to eroding and wire-cut EDM. In addition to the required quality of the parts, productivity and machine availability also play a decisive role with regard to technology, to be able to flexibly process the orders.

**Exclusive Technology Cycle
TURN & MILL/MILLING/MILL & TURN**

ATC 2.0 – APPLICATION TUNING CYCLE

- + Process-oriented adjustment of the feed rate in relation to the table loading
- + Minimization of machining time with maximization of the component quality
- + User friendly setting of the machine dynamics with included DMG MORI knowhow



Equipped with RS 12 rotary storage units for up to twelve pallets, the two DMC 80 U duoBLOCK machines can work efficiently round the clock.

HACK Formenbau rates this reliability of the machining centres from DMG MORI highly in the field of milling. "This was one of the reasons we replaced the two old DMC 80 U duoBLOCK machines with two new successor models of the current generation." The clamping devices, tools and NC programs can be used in the same way, and the improved dynamics and significantly higher performance values are an asset of the state-of-the-art 5-axis milling machines.

RPS 12 ROTARY MAGAZINE FOR SETUP DURING MACHINING AND UNMANNED PRODUCTION

As the workpieces are simply pre-milled on both DMC 80 U duoBLOCK machines for further processing steps, the high precision of the duoBLOCK concept was not even the decisive criterion, as Wolfgang Hack remembers: "What was crucial was productivity". For this reason, both machines were equipped with RS 12 rotary storage units for up to twelve pallets. "This way, we can setup in parallel and produce more or less round the clock – even in the two unmanned shifts." The high capacity of the two machining centres is also enabled by Hack Formenbau having introduced CAM programming in a quiet room directly next to the machines, so that programmers and machine operators can work closely together to optimize the programs. The reliability of the machines is also to be mentioned in this context: "In case of an unplanned downtime, the speedy response of the DMG MORI Service provides support."

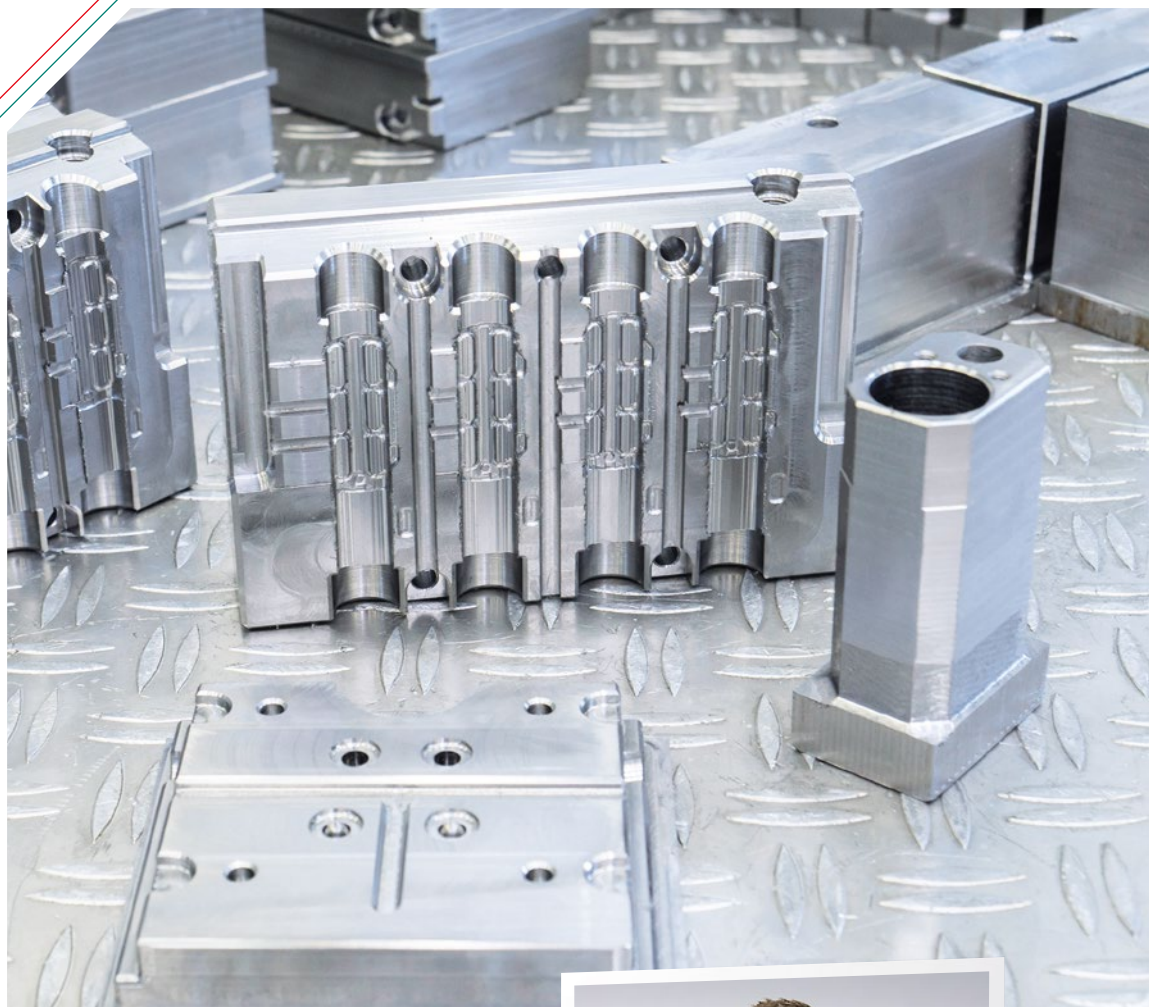

On the DMG MORI DMC 80 U duoBLOCK machines, HACK Formenbau manufactures milled components that are hardened and processed further on surface grinders, die sinking and wire eroding machines.



The high production capacities in machining fit seamlessly into the overall process at Hack Formenbau. Mould proving of the tools on own injection moulding machines with up to 400 tons closing force rounds it off. Another special feature of the company is the technical centre where customers can install their own machines to make new samples of tools. Any work can then be performed on site at Hack Formenbau. Installation of the entire customer production system with automation is also possible during this time. This reduces logistic expenses, if such work can be performed on site at Hack before dispatch. "We can guarantee complete series maturity of the tools with this once they leave our company", Gunnar Hack stresses.

«

As well as accuracy, we most of all value the reliability of the DMG MORI 5-axis machining centers and thanks to the rotary magazine, we can produce virtually around the clock.

Gunnar Hack
Managing Director
HACK Formenbau GmbH

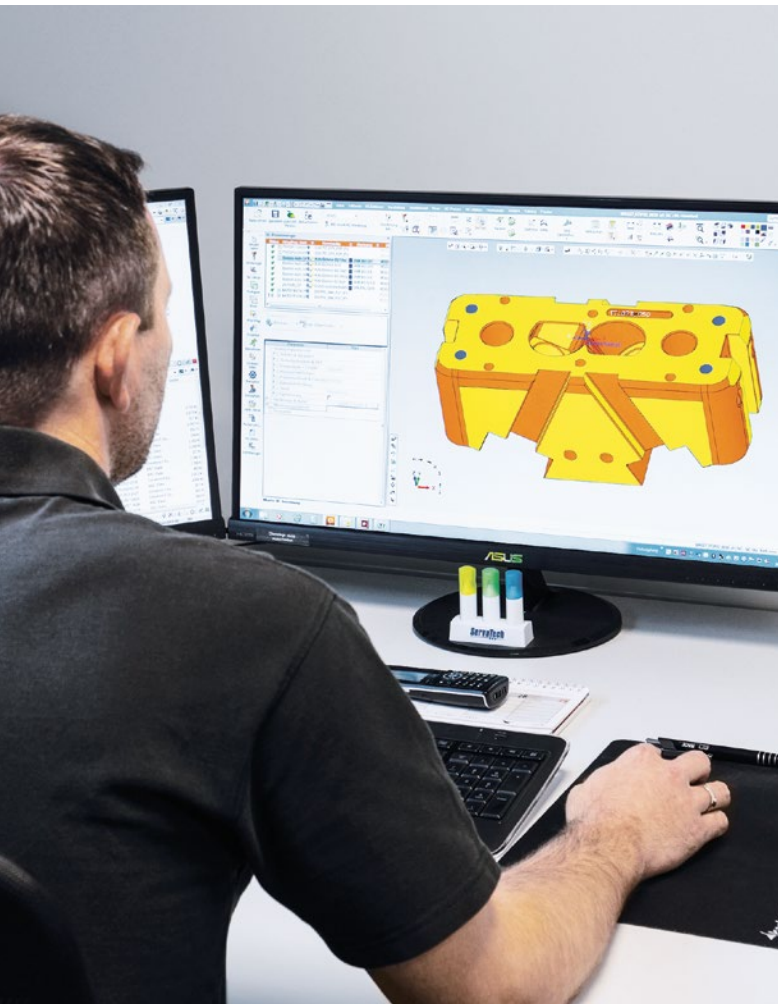

CAM programming occurs in a quiet room near the machines, which enables close cooperation between programmers and machine operators.

HACK FORMENBAU FACTS

- + Founded in 1956 in Kirchheim unter Teck
- + Development and production of complex, high precision molds for plastic injection molding
- + Fully equipped production facilities
- + In-house injection molding machines for testing molds



HACK Formenbau GmbH
 Wielandstraße 11
 73230 Kirchheim unter Teck
 Germany
www.hack-formenbau.de



DMC 90 U duoBLOCK

**WORLD
 PREMIERE
 2019**

**UP TO 10%
 PRICE
 ADVANTAGE**

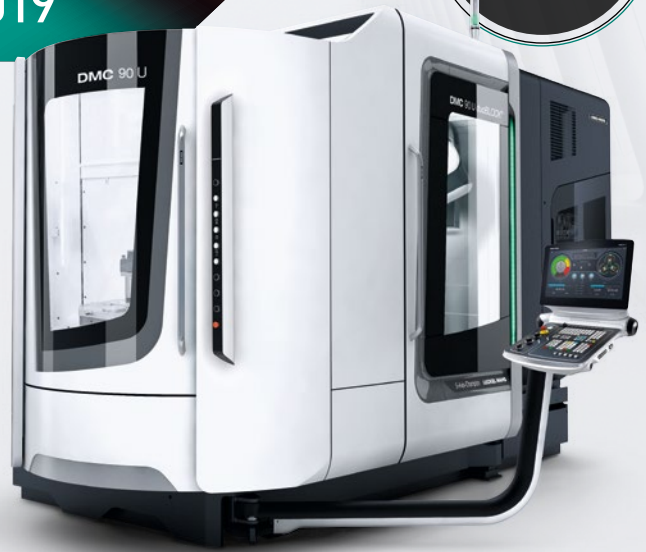

DMC 90 U duoBLOCK

5-AXIS PERFORMANCE PACKAGE

HIGHLIGHTS

- + Delivery time <5 months
- + Top quality at the best price
- + speedMASTER 20,000 rpm spindle with 36-month warranty
- + Integrated digitization with sensor package i4.0 as standard
- + CELOS with SIEMENS or HEIDENHAIN
- + Large HSK-A 100 tool holder with 404 Nm available



speedMASTER spindle with 20,000 rpm and 130 Nm | 35 kW (40% DC).



More about the
 DMC 90 U duoBLOCK
 can be found at:
dmc-90-u-db.dmgmori.com

Schaeffler DuraSense:
Linear axis that can detect
its own wear condition

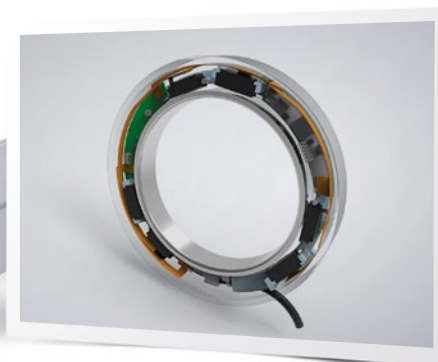
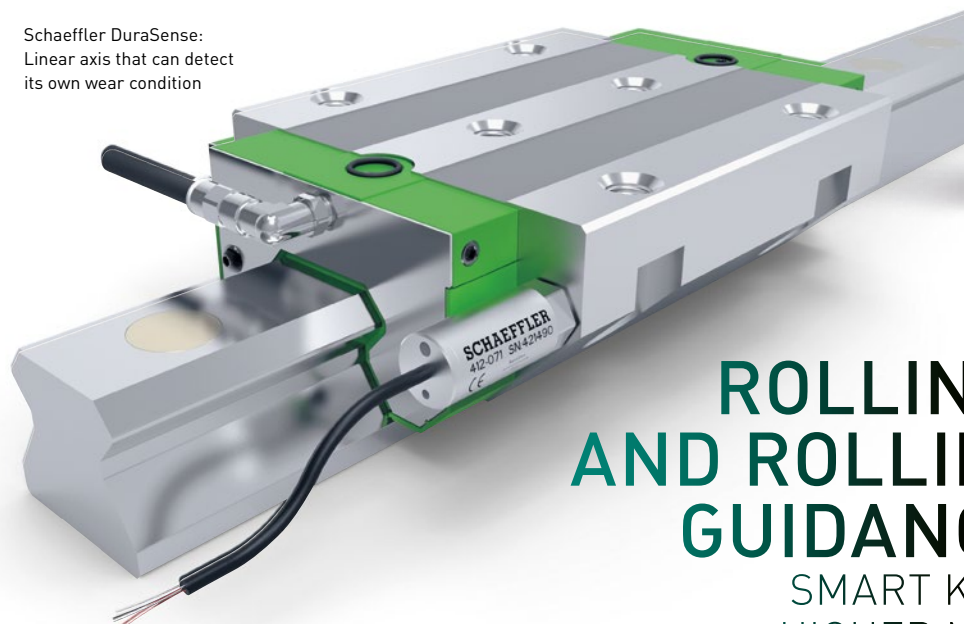

Schaeffler SpindleSense:
Data supplier for motor spindle
overload protection

ROLLING BEARINGS AND ROLLING ELEMENT GUIDANCE SYSTEMS: SMART KEY COMPONENTS FOR HIGHER MACHINE AVAILABILITY

At Schaeffler, they are not just concepts, but concrete development projects: The machine tool of the future will monitor spindle loads arising in the machining process and predict wear of the main axes. Smart rolling bearing monitoring solutions will be the enablers for higher machine availability and productivity.

Spindle bearings as data suppliers

The next generation of spindle bearings will have sensors and – according to the Schaeffler developers – be able to supply characteristic data regarding bearing and spindle loads. Prototypes are already in the test phase at DMG MORI and Schaeffler. A sensor ring on the front spindle bearing with an integrated processing unit determines the spatial spindle displacement and the spindle tilt extremely precisely with a resolution of less than 1 µm. An alarm is output if defined limits are exceeded. The system is used to protect the spindles from overload in the event of a collision. The innovative system is called Schaeffler SpindleSense and will be offered as an option in DMG MORI machines after successful completion of the test phase.

In the next development phase of SpindleSense, the displacement measurement and the bearing model will be used for supplying the spindle bearing utilization in digital form. Through this, the machine operator will be able to detect and minimize the impact of

overload situations and at the same time to fully utilize the load capacity of the machine. This will allow all of the spindle's reserves to be transformed into productivity and revenue.

WEAR-RESISTANT MASTER SPINDLES DUE TO VACRODUR

Linear axes that can detect their own wear condition

With its INA roller monorail guidance systems, Schaeffler is a major supplier for linear axes in DMG MORI 5-axis milling machines. They have a high load carrying capacity and are extremely precise and durable. However, inadequate lubrication and contamination can cause linear guidance systems to fail unexpectedly. The smart solution is monitoring and evaluation of the lubrication conditions in the carriages. The system is called Schaeffler DuraSense and enables, for example, automated requirements-based relubrication, reliable monitoring of manual relubrication, and detection of all defects that can affect lubricant supply – from leaky lines to defective linear guidance system covers. DuraSense announces the impending end of

the service life of the linear guidance system at the appropriate time through shorter relubrication intervals.

Generally speaking, with smart rolling bearing monitoring solutions, rolling bearings will be enablers for higher machine tool productivity, availability, and precision.

«

Schaeffler also relies for its own production on the proven FD (mill-turn) technology of the duoBLOCK series from DMG MORI.

SCHAEFFLER FACTS

- + Founded in 1946
- + More than 90,000 employees throughout the world
- + Around 170 locations in over 50 countries

SCHAEFFLER

Schaeffler Technologies AG & Co. KG
Georg-Schäfer-Straße 30
97421 Schweinfurt, Germany
www.schaeffler.com



X-life
proven to be better

VCM version
With maximum
performance density

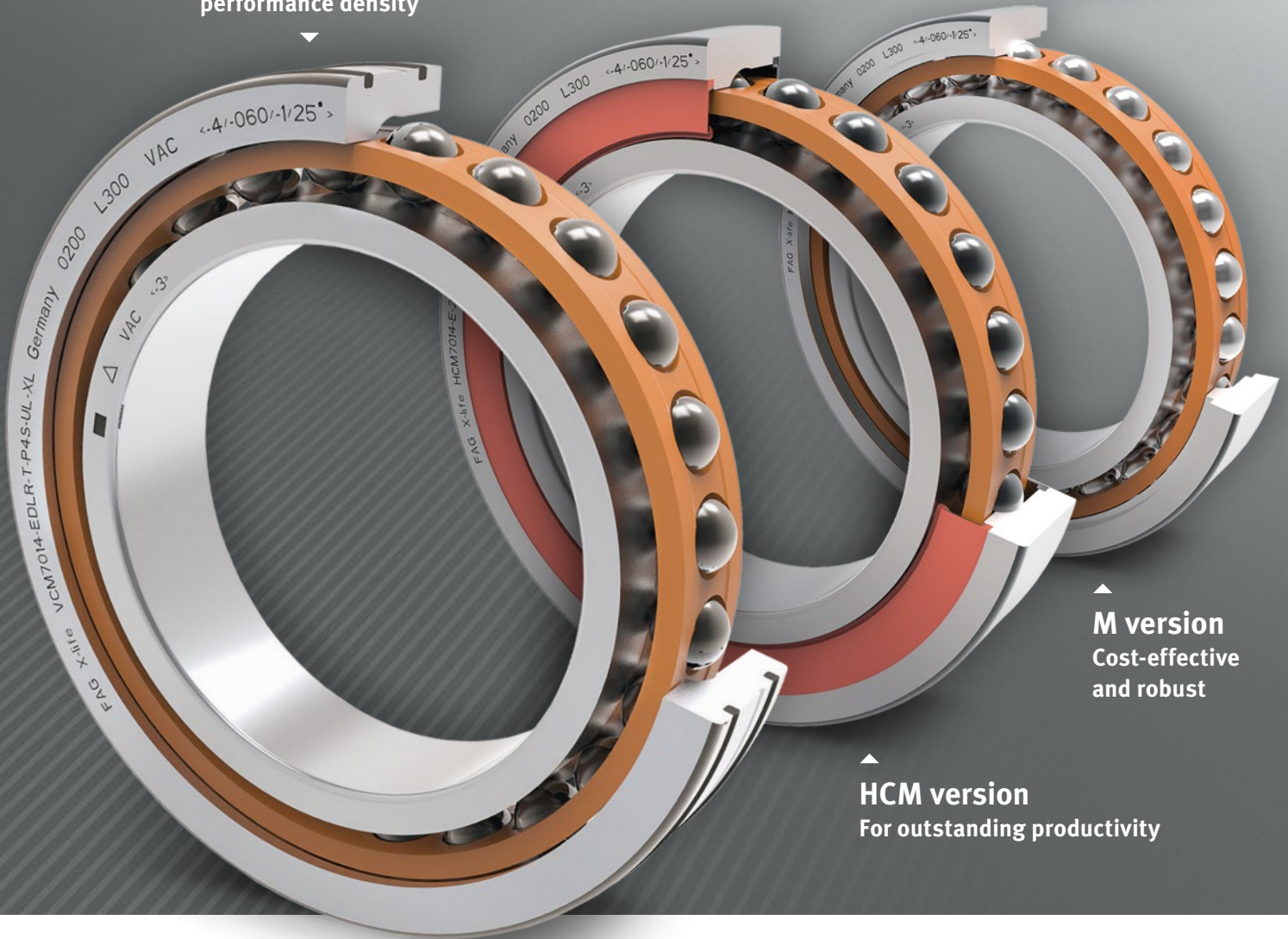

M version
Cost-effective
and robust

HCM version
For outstanding productivity

M-Series High-Speed Spindle Bearings

The X-life High-Speed spindle bearings are available in three versions: For maximum speeds, the highest possible machining forces, and outstanding precision.

VCM version: Made from VACRODUR material for maximum performance and outstanding operational reliability.

www.schaeffler.de/en

 X times longer service life

 X times greater load-carrying capacity

 X times more efficient use of space

FAG

SCHAEFFLER

DMU 200 GANTRY FLEXIBLE HANDLING OF WORKPIECES UP TO 2,000 × 1,350 mm

HIGHLIGHTS

- + **Handling of large workpieces up to 2,000 × 1,350 mm** (automated door opening) and max. 210 kg (including gripper), with < 15 m² additional space requirement
- + **Significant reduction in idle time:** Up to 95% increase in productivity
- + **Individual workpiece arrangement:** Optimum chip management by tilting the workpiece in working area
- + **Customized solutions** for almost all industrial sectors, e.g. Aerospace, Automotive and Die & Mold



AEROSPACE

INTEGRAL PART

Dimensions: 1,750 × 200 × 300 mm
Material: Aluminum
Cycle time: 18 minutes

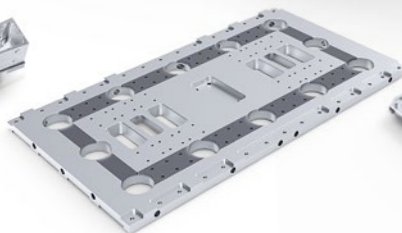

MECHANICAL ENGINEERING

COOLING PLATE

Dimensions: 1,300 × 700 × 40 mm
Material: Aluminum
Cycle time: 31 minutes



AUTOMOTIVE - E-MOBILITY

BATTERY BOX

Dimensions: 1,650 × 900 × 110 mm
Material: Aluminum
Cycle time: 15 minutes



AUTOMOTIVE

STRUCTURAL COMPONENT

Dimensions: 1,400 × 600 × 90 mm
Material: CRP
Cycle time: 4 minutes

DMU 200 GANTRY – SUCCESS FROM THE WORD GO

Since its successful world premiere at EMO 2017, DMG MORI has installed 21 of the DMU 200 Gantry machines in the market. The company Fritzmeier Technologie GmbH was the first customer to have a DMU 200 Gantry commissioned. Fritzmeier Technologie GmbH develops, designs and manufactures high-accuracy components for the automobile industry.

As Fritzmeier had already been involved in the development of the DMU 200 Gantry, the machine could be adapted directly to its production requirements. Furthermore, the excellent collaboration with Fritzmeier and the company's experience have enabled new, useful options and additional improvements to be developed.

Highly dynamic low-gantry machine with 0.5 G

Since the successful commissioning of the DMU 200 Gantry in June 2018, we have mainly been producing aluminum prismatic parts for the automobile industry. We have easily been able to meet all requirements for accuracy and surface quality. Due to the high machine availability of over 93 %, the purchase of the DMU 200 Gantry was a very good decision. Furthermore, we are so pleased with DMG MORI's gantry concept that we have ordered the larger DMU 340 Gantry, which will be installed by the end of 2019.



Robert Huber
Managing Director
Fritzmeier Technologie GmbH

DMU 200 Gantry with WH 210.



Die & Mold: 5-axis simultaneous machining of an aluminum mold insert.



Find out more about the DMU 200 Gantry here:
dmu-200-gantry.dmgmori.com



Using 180 DMG MORI machines – among them ten HSC 55 *linear* for high-speed cutting and five LASERTEC 45 Shape for surface structuring – OMCO manufactures highly precise glass molds.

HSC AND LASER STRUCTURING FOR GLASS MOLDS WITH FINE DETAILS

Since its founding in 1964, just as the industrial production of glass containers started to gain momentum, OMCO has become the leading supplier of molds for the manufacture of glass bottles. The company is a subsidiary of the Belgian BMT Group. After years of rapid growth, it now has 1,800 employees at sites in Belgium, Croatia, Romania, England, Turkey and Slovenia. OMCO meets the high demands on machining both for turning as well as milling with around 180 DMG MORI machine tools, amongst others. Since 2012, a total of ten HSC 55 *linear* and five LASERTEC 45 Shape have been used in factories in Croatia, Romania and Turkey. OMCO achieves excellent surface quality with high-speed cutting, which significantly reduces the amount of manual post processing required.

From design of the mold to the finished product

“We find ourselves in a growth market with our molds for glass bottle production,” says Darko Ranogajec, CEO of the OMCO Group, assessing the economic situation. Consumers and beverage manufacturers consider glass to be a sustainable alternative to plastic bottles. Although glass is associated with higher

energy consumption, the stable bottles can be reused many times and recycling also works well. “Plastic bottles will never disappear from the market, but the overall consumption of glass will continue to increase.” The design of the bottle plays a major role in many new markets.

Over 70 percent of the glass molds that OMCO produces are intended for the beverage and food industry, but customers are also in the cosmetics and medical sectors. The range goes from molds for 5 ml bottles up to large

HIGH DYNAMICS
WITH 2G AND
RAPID TRAVERSE
UP TO 80 m/min

15 liter containers. OMCO is a full-service partner for its customers. Darko Ranogajec about the service portfolio: “We provide advice on the technical feasibility of the bottle design, engineer the molds and manufacture

them – from casting through machining to the finishing process.” The majority of the molds are made of cast iron, but some are made of durable and difficult-to-machine aluminum-bronze alloys.

Highly dynamic and high precise, thanks to HSC machining

OMCO realizes efficient manufacturing processes with an extremely diverse range of machines. Amongst others, DMG MORI alone has supplied turning machines from the NRX series, milling-turning centers and LASERTEC Shape machines for laser engraving. The array of machines also includes the HSC 55 *linear* for high-speed cutting. “The HSC 55 *linear* is intended to further optimize our processes when it comes to machining speed and precision,” explains Darko Ranogajec. Linear drives enable dynamic acceleration of up to 2G and rapid traverses of maximum 90 m/min. The 40,000 rpm HSC spindle ensures the best-possible surface quality.



The HSC 55 *linear* manufactures complex molds precisely and efficiently.



Optimized processes thanks to high-speed cutting that combines speed and precision in an ideal way.

Darko Ranogajec
CEO of the OMCO Group

Minimum polishing effort thanks to HSC 55 *linear*

"HSC machining has allowed us to achieve our goal of surface quality so good that the requirement for subsequent polishing is kept as low as possible," is how Darko Ranogajec explains the HSC technology. The ratio of machining time for the HSC 55 *linear* to the time needed for polishing is optimal. The 5-axis HSC 55 *linear* also demonstrates its strengths for OMCO when it comes to complexity. "Bottle designs are becoming increasingly more sophisticated," says Darko Ranogajec. This requires a versatile machine that can precisely profile even the finest details in the molds.

LASERTEC Shape for unlimited design freedom

The increasing degree of complexity was also a reason why OMCO uses machines from the LASERTEC Shape series by DMG MORI – five LASERTEC 45 Shapes – for surface structuring of molds. Reproducible and clearly defined structures are created by means of laser material removal – economically, quickly and with considerably less environmental impact than was possible by etching. "The considerable design freedom afforded by LASERTEC Shape technology offers us a lot of scope in the design of glass molds," says Darko Ranogajec.

OMCO FACTS

- + Founded in Belgium in 1964
- + 1,800 employees at sites in Belgium, Croatia, Romania, England, Turkey, and Slovenia
- + Production of glass molds for the food and beverage industry as well as the cosmetics and medical sectors



OMCO International
Venecolaan 10
9880 Aalter, Belgium
www.omcomould.com



«

More productivity for production with machine tools

CNC Shopfloor Management Software

Job preparation and execution

Production efficiency and flexibility

Machine availability

Machining process improvement

Ingenuity for life

siemens.com/machinetools-digitalization

NEW DMQP PARTNER

FOR HIGH-PERFORMANCE MICRO-MACHINING WITH INTERNAL COOLING



Titanium bone plate



DMP 70

MEDICAL PACKAGE

HIGHLIGHTS

- + Workpieces up to **400 kg** in a footprint of **<4.3 m²**, X, Y, Z = 700 × 420 × 380 mm
- + **Stainless steel covers** in the work area
- + **inlineMASTER-Spindle with 24,000 rpm** and 20 Nm
- + Swivelling rotary table for **5-axis simultaneous machining up to 100 kg**, incl. DMG MORI technology cycle 3D quickSET and ATC – Application Tuning Cycle
- + **toolSTAR** tool magazine with **25 pockets**
- + Chip conveyor and space saving **40-bar internal coolant system**
- + Tool measurement and measuring probe
- + **Oil machining package** incl. fire **extinguisher system**

DMG MORI has found a new partner for its DMG MORI Qualified Products Program in the Swiss toolmaker Mikron Tool. The products of Mikron Tool now carry the DMG MORI seal of quality for premium accessory components. The DMQP portfolio has been expanded to include high-precision tools for the micro-machining of hard-to-machine materials such as stainless and heat-resistant alloys, titanium alloys or cobalt chrome. Core target industries for Mikron tools with a diameter of 0.2 to 8 mm include medical technology and watchmaking as well as the automotive and aerospace sectors.

Mikron Tool has already been working closely with the DMG MORI Medical Excellence Center in Seebach for about three years. Substantial increases in productivity have been achieved in customer projects thanks to the intensive exchange of technology and experience. The machining of a titanium bone plate on a DMP 70, for example, impressed visitors

attending the Medical Days at DMG MORI in Seebach on 14th and 15th May 2019. The “Crazy” tools from Mikron Tool surpassed all benchmark specifications for process reliability, machining time and service life.

Ø0.32 mm – including internal cooling channels for longer service life

The special feature of the “Crazy” tools is that they are always cooled internally through the shaft, in some cases even through the tip of the tool. “In contrast to an external cooling jet we achieve consistent cooling of the cutting edge with no temperature shock, which in turn leads to longer service life”, explains Dr. Alberto Gotti, Head of Research and Development at Mikron Tool. In addition the flushing of chips from the workpiece is considerably more efficient and reduces the risk of fire, in particular when machining titanium. This internal cooling is available from a tool diameter of 0.2 mm.



“Crazy” tools with internal cooling channels and a diameter of 0.2 to 8 mm.



6-SIDED COMPLETE MACHINING OF A FIXATION SCREW

Dimensions: $\varnothing 4 \times 20$ mm

Material: Titanium

SPRINT 2018: 110 sec.



Early involvement of customers in the DMG MORI Medical Excellence Center

Experts in the DMG MORI Medical Excellence Center work with customers to develop and realize integral technology solutions, to define effective automation solutions for maximum quality and autonomy and to ensure processes with digitized procedures. The relevant peripherals and accessory components from the DMG MORI Qualified Product Program are used in a targeted manner. The programming system from SIEMENS NX CAM, workholding devices from Schunk, a high-pressure coolant system from Bürener Maschinenfabrik and high-precision tools from Mikron Tool were all used in the demonstration of the titanium bone plate application presented during the Medical Days event.

Mikron Tool Technology Center with DMG MORI expertise

As a consequence of the increasing exchange of technology with DMG MORI, Mikron Tool changed over to machine tools from DMG MORI in the technology center at its headquarters in Agno – including a SPRINT 2018, a DMU 60 eVo and the new DMP 70. “Thanks to our close collaboration in the technology center of Mikron Tool, we are now in a position to use our joint know-how to provide customer-oriented support in particular for users in Switzerland and Italy.”, says Marcus Krüger, Global Key Account for Medical at DMG MORI. He is especially pleased that Mikron Tool has been awarded the DMG MORI Qualified Product seal of quality and that its high-precision micro-machining expertise is now available for all DMG MORI customers worldwide.

MIKRON TOOL SA FACTS

- + Founded in 1998 as a “spin-off” from the in-house Cutting Tools department of Mikron SA Agno
- + “CrazyDrill”, launched in 1999 as the fastest small drill bit in the world, are available as “Crazy-Drill Cool” with internal cooling
- + In 2013 Mikron Tool sets a milestone in milling technology with the launch of the “CrazyMill Cool”: hard-to-machine material like titanium or CoCr can be machined up to 20 times faster

Mikron Tool 

Mikron Tool SA Agno
Via Campagna 1
6982 Agno, Switzerland
www.mikrontool.com



Horst Lindner
Head of the Medical Excellence Center
horst.lindner@dmgmori.com

EARLY INVOLVEMENT OF CUSTOMERS IN THE DMG MORI MEDICAL EXCELLENCE CENTER

- + **Development and consultation for and with our customers:** greenfield consultation, process development, consultation for regulatory issues, etc.
- + **Full-service provider – machine, automation and technology from a single source:**
 - Turning, milling and advanced technologies such as ULTRASONIC or additive manufacturing
 - Automation incl. Digital Twin for the Green Button Process
- + **Integral Process Chain** – from PRODUCTION PLANNING with ISTOS, to CAD/CAM programming with NC CAM and on through to production

PRODUCTION OF COMPLEX SURGICAL INSTRUMENTS TO WITHIN MICRONS ON 14 DMU eVo MACHINES

Orthopedic instruments made of carbon and stainless steel have been the core business of Moll Engineering GmbH from Lübeck for over 20 years. Since 1998 production of orders from industry giants such as Stryker has taken place in Wenglon GmbH, Dobra near Stettin in Poland, a company founded solely for such production. At the beginning of 2019 Ensinger GmbH from Nufringen – which had supplied Moll with CFRP materials for many years – took over both companies including all 80 employees, thus enabling new investment and further growth. Two DMU 60 eVo *linear* machines from DMG MORI, for example, were recently installed at Wenglon, bringing the number of models in operation from the machine tool manufacturer to 16, including 14 high-tech machines from the DMU eVo series.

PRODUCTION TO WITHIN MICRONS

“The great expansion of producers in medical technology has in turn led to enormous growth for us as contract manufacturers serving the industry”, says Stefan Moll, Managing Director of Moll Engineering and Wenglon with a smile. “In order to remain

competitive we have to optimize our processes continuously and this means investing in production technology and in the training of our employees.” In this respect he views the takeover by the plastics company as a stroke of luck and a win-win situation for all concerned: “Ensinger has enhanced its value added chain with our manufacturing competence. We can invest more and therefore supply a larger customer base.”

X-ray transparent instruments made of carbon

The Moll Engineering product range includes in particular complex surgical instruments made of carbon and stainless steel. The reasons for using CFRP are its stiffness and low weight, but even more important is that it is X-ray transparent. “These properties have made such instruments into bestsellers in the medical technology industry”, says Stefan Moll.

DMU eVo *linear* – 5-axis simultaneous machining to within microns

The tolerances of the parts are often to within microns, while the exotic materials place maximum demands on machines and tools. Added to this is the complexity of the components. “Trained specialists are needed for the efficient and quality-oriented handling of production processes on the modern machine tools”, Stefan Moll tells us.



Thanks to the support of the DMG MORI Medical Excellence Center we were able to reduce our process times by up to 30%.

Stefan Moll
Managing Director of
Moll Engineering and Wenglon

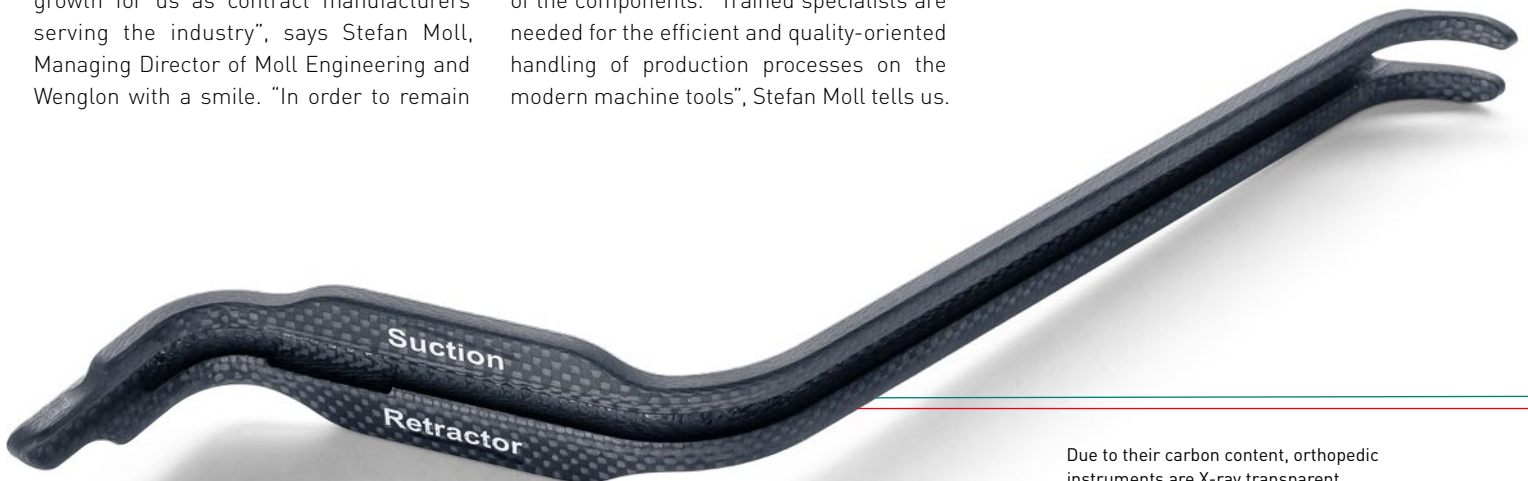

Due to their carbon content, orthopedic instruments are X-ray transparent.

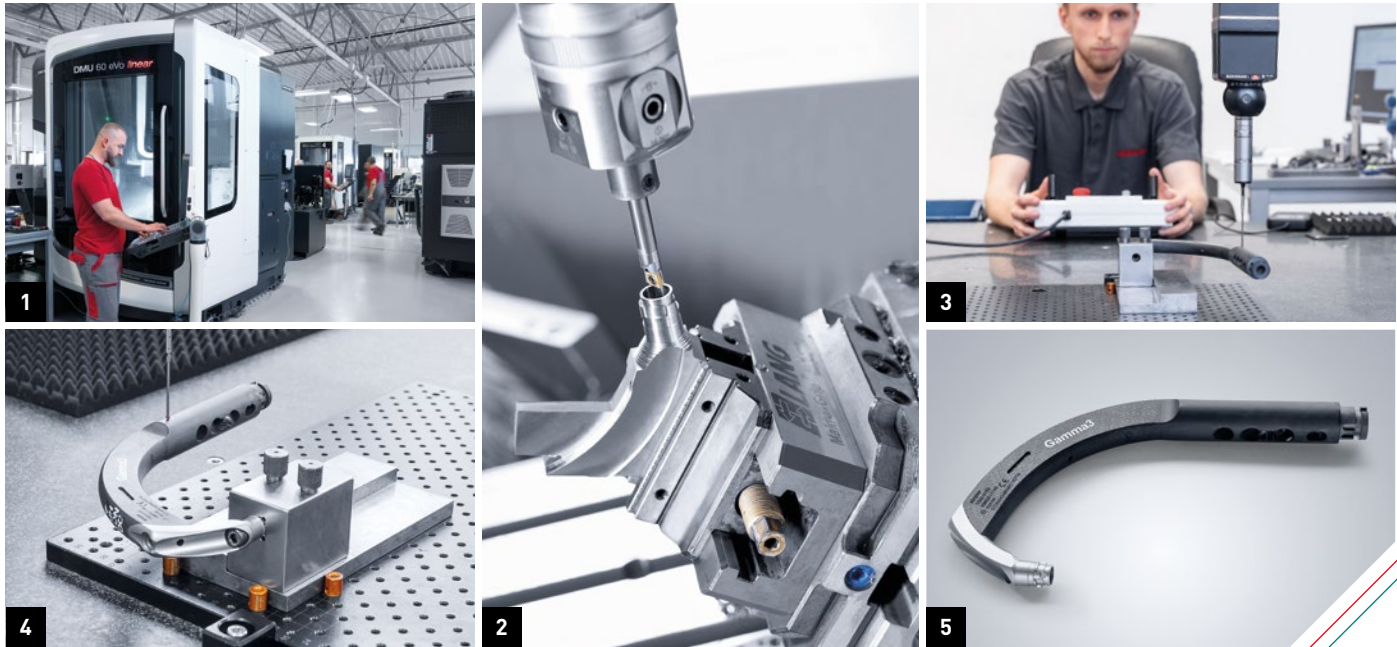

1. The DMU 60 eVo *linear* installed in 2019 is just one of 14 machines from the successful DMU eVo series at Wenglon. 2. Wenglon machines demanding materials such as carbon and stainless steel on the 5-axis DMU eVo machines. 3. + 4. The tolerances of the medical technology products are often to within microns. 5. Moll Engineering has worked closely with the DMG MORI Medical Excellence Center in Seebach on the process optimization of demanding and high-precision components.

Primarily machines from the 5-axis DMU eVo series have been employed since 2000. The swivelling rotary table with a -5° to $+110^\circ$ B-axis enables efficient 5-axis simultaneous machining. DMU eVo machines are also stable and guarantee top precision.

Linear drives and speedMASTER spindles with 36-month warranty

"The latest models on our shopfloor are all DMU eVo *linear* machines", says Stefan Moll citing the enhanced accuracy attainable using linear drives. The required milling performance is provided by the 20,000 rpm speedMASTER spindle included in the standard version. Moll Engineering and Wenglon are so satisfied with the series that two new DMU 60 eVo *linear* machines were just recently installed at Wenglon in 2019 to help cope with the continuously rising capacity requirement.

Process optimization in the DMG MORI Medical Excellence Center

Moll Engineering also maintains a close relationship with the DMG MORI Medical Excellence Centre in Seebach, as Stefan Moll explains: "We have worked closely on several occasions, especially where the process optimization of demanding and high-precision components is concerned, and received support from DMG MORI in programming

with NX CAM. DMG MORI experts were able to reduce process times by up to 30 percent. Short cycle times mean we can deliver faster and this in turn strengthens our competitive edge."

Competitive thanks to maximum machine availability and good service from DMG MORI

Competitive capacity is directly dependent on machine availability. "We trust in the extremely reliable machine tools from DMG MORI", claims Stefan Moll. However, the machine supplier is called in if there is a stoppage: "DMG MORI Poland has optimized its service to such an extent that we receive help immediately whenever we need it."

Growth through investment

Thanks both to its expertise and the Ensinger takeover, Moll Engineering and Wenglon have created a sound basis for future growth in the medical technology sector. Stefan Moll looks ahead optimistically: "Another DMU 60 eVo *linear* will be installed at the end of the year and we have long-term plans to expand our production area."

MOLL ENGINEERING FACTS

- + Over 20 years of experience in the production of orthopedic instruments made of carbon and stainless steel
- + Wenglon was founded as an independent company in Poland in 1998
- + 80 employees in Lübeck and Dobra
- + Supply of industry giants such as Stryker



MOLL ENGINEERING GmbH
Seelandstr. 14-16
23569 Lübeck, Germany
www.moll-engineering.de



LASERTEC 30 SLM 2nd GENERATION HIGH-PRECISION PRODUCTION OF COMPLEX FORMS WITH < 6 μm SURFACE QUALITY

**FIRST
TIME RIGHT**
The new OPTOMET
software for
parameter
optimization



rePLUG
powder module

LASERTEC 30 SLM 2nd GENERATION

GENERATIVE MANUFACTURING IN A POWDER BED WITH A 300 × 300 × 300 mm BUILD VOLUME

HIGHLIGHTS

- + Highly complex components with function integration
- + Internal conformal cooling channels
- + Weight reduction due to topology optimization, lattice and honeycomb structures
- + High-precision build of 3D components with dynamic adaptation of the focus diameter between 70 μm and 200 μm plus layer thicknesses in the 20 – 100 μm range
- + rePLUG – The powder module for fast material change in <2h

Azuma Kinzoku Sangyo Co. Ltd. was established as a foundry in 1942 in Omori, Ota-ku, Tokyo. It moved to Numazu in 1951, where customized sheet metal forming was added as a second business area in addition to the foundry. Its expertise includes production processes in which deformation can be taken into account or prevented early on during processing. It is one of the few companies in Japan that processes MMC materials (Metal Matrix Composite) – and it does so in compliance with all applicable quality standards. Azuma's latest business field is additive manufacturing.

Kentaro Tanaka, 3rd generation manager of the company, has been looking into additive manufacturing processes for metal since 2014 and is extremely enthusiastic about Additive Manufacturing (AM), because: "Due to our many years of experience in foundry technology we know a lot about materials, forms and geometries. The future of our production will be additive manufacturing, because this is where we can make the best use of our strengths."

DMG MORI has emerged as the best partner for additive manufacturing

Kentaro Tanaka scrutinized the different manufacturers extensively before procuring his first additive manufacturing machines. He was supported by the General Manager of the AM Division, Shinya Okuma, who joined the company as an AM specialist. Until 2017 it was very difficult to convince customers of the quality of additively manufactured products and to gain orders in this area. However, more and more machine producers then started to take an interest in this type of manufacture and the situation changed radically. Kentaro Tanaka has experienced

rePLUG POWDER MODULE FOR A RELIABLE POWDER CHANGE PROCESS

a consistent increase in generatively manufactured products. While striving to expand this business field further, he kept a close eye on developments at DMG MORI. His interest was aroused in particular by the participation in REALIZER GmbH in Germany, a company with over 20 years of experience in additive manufacturing. "We heard that DMG MORI was going to bring out a new product offering functions that other manufacturers had not even considered. This information aroused our curiosity," says Kentaro Tanaka.

rePLUG – safer and faster Material change in less than two hours

In 2018 Azuma Kinzoku Sangyo installed the first LASERTEC 30 SLM 2nd Generation

Complex, lightweight geometries can be produced with the LASERTEC 30 SLM 2nd Generation.



Surface qualities of Ra < 6 μm during additive manufacturing can only be achieved on DMG MORI machines.

Kentaro Tanaka
President
Azuma Kinzoku Sangyo Co. Ltd.



machine in its production facility, which was also the first such machine in Japan. Powder bed technology for additive manufacturing of metal parts enables a reduction in the weight of workpieces through topology optimization, the manufacture of complex forms and the production of internal channel structures. These capabilities cannot not be realized with metal removal processes. "We found the "rePLUG" powder module system for material change particularly attractive. Thanks to this module the powder can remain in a closed container, thus preventing any damage to health caused by breathing in powder. Most of all I appreciate the "safety first" concept, which complies exactly with my own attitude. Economic handling of the expensive materials and the higher degree of efficiency achieved through the time saving are, of course, other advantages of the LASERTEC 30 SLM 2nd Generation," adds Mr Tanaka.

LASERTEC SLM for unrivaled surface quality with Ra < 6 μm

Shinya Okuma, who works regularly with the machine, shares his impressions with us: "When it came to manufacturing a waveguide that could not be produced by milling or other subtractive processes, we were surprised by how the LASERTEC 30 SLM 2nd Generation was able to exceed the required surface quality of Ra = 6 μm, while machines from other manufacturers could not achieve better than Ra = 8 μm. As far as I know, such precision can only be realized with LASERTEC machines from DMG MORI. With its intuitive operation, the CELOS control and operating system also contributes to optimum usability."

DMG MORI as an integral partner for additive manufacturing

Azuma Kinzoku Sangyo now regularly receives follow-up orders for prototypes and components from the automotive and aerospace industries. Kentaro Tanaka has set his expectations higher in view of this positive business development: "Sales in the AM division are 150 % higher than in the previous year and it looks as if this is just the beginning. Additive manufacturing is regarded as mainstream for production in the automotive sector. This offers the chance of a sharp rise in production using AM in the next five to ten years. That is why we are continuously attempting to gather more expertise, so we can open a new business field as a consultant in the commissioning of AM plants. We are absolutely convinced that DMG MORI will prove a reliable partner in this undertaking."



l-r: President Kentaro Tanaka, General Manager of the AM Division, Shinya Okuma and Operator Hidehiko Sasaki in front of the LASERTEC 30 SLM 2nd Generation.

AZUMA KINZOKU SANGYO CO., LTD. FACTS

- + Founded in 1942
- + Diverse production technologies: casting, machining and sheet forming. NEW: Entry into additive manufacturing.
- + Familiar with every type of material, provides suggestions for the improvement of processes for workpiece manufacture, taking material quality into consideration, for numerous customers in many different industries



Azuma Kinzoku Sangyo Co., Ltd.
Zentrale / Werk Numazu
1281-3, Ooka, Numazu-City,
Shizuoka, 410-0022, Japan
www.azuma-ks.co.jp





POWDER CIRCULATION

OPEN,
CONTINUOUS,
QUALIFIED

No lock-in – qualified partners for a free choice of peripherals and powder.

Christoph Grosch
Head of DMQP
Beteiligungen GmbH
christoph.grosch@dmgmori.com

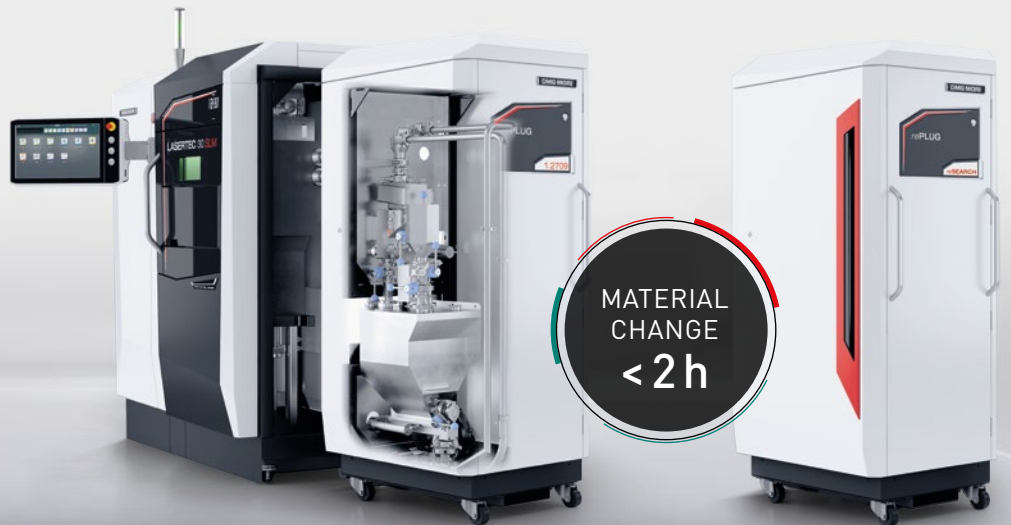

POWDER RANGE

POWDER RANGE

- + 1.2709 (tool steel)
- + 1.4404 (stainless steel)
- + AlSi10Mg0.5 (aluminum)
- + CoCr ASM F75 (cobalt chrome)
- + CoCr (Starbond CoS powder 55, dental)
- + Inconel® 625
- + Inconel® 718
- + Ti6Al4V or 3.7165 (titanium)

LASERTEC SLM with rePLUG

The powder module for rapid material change and automated powder handling



READY-TO-USE

Provision of material and process parameters

DELIVERY

Within 3 days (EU-wide)

QUALIFIED

Compliance with all required QA standards
Powder reduction on a LASERTEC SLM

SIMPLY ORDER ONLINE

The whole powder range is available from the DMG MORI Online Shop:
shop.dmgmori.com

**WORLD
PREMIERE
2019**

**ADDITIVE MANUFACTURING
LASERTEC 125 3D hybrid**

- + **NEW:** Maintenance, repair, coating and new part production up to diameter 1,250 mm and 2,000 kg
- + **NEW:** AM Assistant – for unmanned, reliable and transparent production

HIGHLIGHTS

- + Combined laser deposition welding and milling
- + Automatic changeover between additive and milling operations in a single setup
- + Complete hybrid CAD/CAM process chain
- + AM Assistant: adaptive process control, powder feed rate sensor, AM evaluator, AM guard for maximum quality and process security



WORLD PREMIERE
formnext
FRANKFURT
18. – 22.11.2019



REPAIR

Forging die – reduction in tool sets due to a reduction of up to 80% in processing time



NEW PRODUCTION

Blade – 90% weight reduction thanks to lightweight structures and multi-material



MAINTENANCE

Cutting tool – up to HRC 63 without heat treatment



REPAIR

Pressure die casting core – 3-times normal service life due to the use of multi-material



SPARE PART PRODUCTION

Valve – minimum system downtime resulting from a 90% reduction in replacement lead-time



NEW PRODUCTION

Closed impeller: 10% higher performance owing to new design



Find out more about the LASERTEC 125 3D hybrid at: lasertec-3d.dmgmori.com

SIEMENS
Ingenuity for life



Utilize the potential of Additive Manufacturing with NX and SINUMERIK.

siemens.com/additive-manufacturing

DMG MORI ACADEMY

WORLD BIGGEST CNC ACADEMY WITH
20,000 TRAINING PARTICIPANTS PER YEAR



ACADEMY FACTS

- + 16 training centers worldwide
- + > 85 training machines
- + > 150 certified trainers
- + > 20,000 training participants per year
- + Modular training concept with > 200 courses
- + Global Industry Partner of WorldSkills International and Sponsor of WorldSkills Kazan 2019



Jan Möllenhoff
Managing Director
DMG MORI Academy
jan.moellenhoff@dmgmori.com

DMG MORI Academy GmbH
Gildemeisterstraße 60
33689 Bielefeld, Germany
www.academy.dmgmori.com



Most recently, DMG MORI was the main sponsor of the World Championship of professions in Abu Dhabi 2017.



WORLDSKILLS – PROMOTION OF YOUNG TALENTS ON WORLD CLASS LEVEL

- + Sponsorship of WorldSkills Competitions since 2007
- + Global Industry Partner of WorldSkills International since 2016
- + Platinum partner of the World Cup in Kazan 2019 with 45 high-tech machines for the competitions
- + Main sponsor of WorldSkills Shanghai 2021
- + Perfect preparation of the participants with DMG MORI machines and training

CNC EDUCATIONAL LABS



CNC LAB SILVER

- + DMG MORI Programming and Training Software
- + DMG MORI Training Consoles
- + Didactical training materials
- + Train-the-Trainer concept
- + Special WorldSkills Trainings
- + Curricula for state-of-the-art industrial training

CNC LAB GOLD

- CNC Lab silver, plus:
- + CLX 350 V3
 - + CMX 600 V (3-axis)
 - + Haimer UNO 20|40 Premium
 - + CAD/CAM Classroom
 - + CAD/CAM Training
 - + Advanced Training for industry parts production

CNC LAB PLATINUM

- CNC Lab Gold, plus machine upgrade to:
- + CTX alpha 500 (complex turning operations)
 - + DMU 50 (5-axis)
 - + Advanced Training for high-end parts production
 - + Training for Industry 4.0



Opening ceremony with (from l. t. r.) Christian Thönes (Chairman of the Board, DMG MORI AKTIENGESELLSCHAFT), Dr. Khaled Abdel Ghaffar (Minister of Higher Education and Scientific Research, Egypt) and Dr. Ashraf Mansour (GUC, Prime Founder & Chairman of Board of Trustees).



GUC – GERMAN UNIVERSITY IN CAIRO

- + Opening of the new Technology Center at the German University in Cairo in January 2019
- + Common know how for production engineering and training
- + 15 installed DMG MORI machines
- + 3 training rooms for programming, CAD/CAM, machine training (basic, advanced, expert), etc.

MACHINE AND FINANCE FROM A SINGLE SOURCE



Pierre Lindner (left) from DMG MORI Finance and Christian Müller discussing new projects: DMG MORI Finance is characterized by customer-oriented finance models and trusting cooperation.

MWF Technik GmbH & Co. KG of Siershahn in Westerwald quickly established itself as a reliable and competent partner in plastic and metal technology after it was established in 2005. More than 30 specialists develop and produce complex workpieces and assemblies for the chemical industry, laboratory and medical technology as well as mechanical engineering. The range of services is rounded off by subcontract production of metal components and a range of in-house products. From the very beginning, DMG MORI supplied the required accurate milling machines and turning centres. DMG MORI Finance is also on board with its made-to-measure and uncomplicated finance models. These allow MWF Technik to concentrate fully on production.

Both as a service provider in development and manufacturing and also with its own products, MWF Technik is experiencing successful and high-growth business development. "Our original goal of taking on one new employee per annum has long since been exceeded", says Christian Müller. He manages the company together with Klaus Peter Wagner, who reveals the reason: "We have always grown alongside our customers." For this reason, after a few years they constructed a larger building and extended it again to a total of 2,000 square meters in 2017, providing space for the 15 machine tools from DMG MORI that the company now has.

Modern and powerful manufacturing technology from DMG MORI

Christian Müller knew about the machine manufacturer from a previous job: "The extensive product range, the reliability of the machines and their precision were decisive reasons for us to cooperate with DMG MORI." The precision of the workpieces is a few micrometers in some cases, and versatile 5-axis machining centres or lathes with milling functionality are needed for the complex geometries. The ASM shop floor at MWF Technik looks like a DMG MORI showroom: A versatile DMU 50, a DMU 60 eVo and a DMU 75 monoBLOCK stand out in the milling area. It is mainly the high-stability models in the NLX model series that are in use in the turning area. This modern and powerful

DMG MORI Finance allows financing without additional collateral.

Klaus Peter Wagner (left) and company founder **Christian Müller**
MWF Technik GmbH & Co. KG



FINANCE

Your machine utilization sets the rates

More information about DMG MORI economic program on page 14

manufacturing technology from DMG MORI helps MWF Technik to fulfil the high demands of customers and remain competitive.

Reliable and flexible with DMG MORI finance solutions

The procurement of new machine tools involves investments that smaller and younger companies such as MWF Technik weigh up in detail. To Christian Müller, it is all the more important to have a trustworthy and flexible finance partner: "We have found such a partner in DMG MORI Finance." The subsidiary of the technology leader accompanies customers during the procurement process of a machine solution and supports them with individual finance models. Klaus Peter Wagner adds: "The fact that DMG MORI and DMG MORI Finance provide the machine and the finance from a single source is very important to us, because we can invest independently of our company bank."

being produced: "The terms and amounts of the monthly instalments can be individually adapted, which gives us a great deal of flexibility in our financial planning."

As well as leasing and hire purchase, the quote from DMG MORI Finance also includes rental with the option of handing back the machine at the end of the term. In the case of lease finance, MWF Technik will be able to purchase the machine at the end of the leasing agreement. A binding agreement to purchase the residual value could have tax consequences, so should not be "officially" communicated at this point. "After all, we know the high value retention of the machines", explains Klaus Peter Wagner. In the event of hire purchase, a model which MWF Technik has also used, the machine is in the machine is the property of the customer from the start of the contract, i.e. in a broader sense hire purchase is purchasing in instalments. Regardless of the chosen contract, DMG MORI Finance offers reduced rates during the first six to twelve months in order to give the new machine time to deliver full productivity. Special repayment terms are also possible during the contract period.



13 of the 15 DMG MORI machines were procured with the support of DMG MORI Finance.

FLEXIBLE TERMS AND RATES

Customer-specific financing and leasing

Christian Müller admits that the company bank may offer more favorable terms, but: "The company bank needs 40 percent of the purchase price as security for every finance deal." DMG MORI Finance, on the other hand, understands that the machines are valuable assets and regards them as providing the required security. "This also applies to peripherals from external suppliers." DMG MORI Finance financed the automation solutions bought in 2018 for the DMU 50 without any additional collateral. Klaus Peter Wagner praised the flexibility when the offer was

Finance partner for the future

The support provided by DMG MORI Finance has allowed MWF Technik to make 13 new investments in the last few years. Christian Müller and Klaus Peter Wagner agree that this cooperation will continue to be an integral part of new acquisitions in the future: "The good relationship regarding trust has played a major part."

MWF TECHNIK FACTS

- + Established in Siershahn in 2005
- + 30 skilled workers
- + Development and production of complex workpieces and assemblies
- + Chemical industry, laboratory and medical technology, mechanical engineering



MWF Technik GmbH & Co. KG
Halsschlag 9
56427 Siershahn, Germany
www.mwf-technik.de



You can find the video to this customer story at:
www.dmgmori.com/mwf

“YOUR ONLINE SERVICE MANAGER”



my DMG MORI
The new customer portal
for service optimization

MORE SERVICE

- + **No waiting:** Simple online description of the problem
- + **Prepopulated service requests:** Include machine details, photos or videos

MORE KNOWLEDGE

- + **Complete machine history:** All events related to the machine can be systematically called up
- + **All documents are digital:** Library for technical and commercial documents available

MORE AVAILABILITY

- + **Free access 24/7:** From anywhere at any time
- + **On every device:** Computer, smartphone or via CELOS

*myDMGMORI is only available in member states of the European Union.



After EMO
register free at:
myDMGMORI.com

SAVE THE DATE

- + **formnext, Frankfurt / Germany:** November 19 – 22, 2019
- + **OH Pfronten / Germany:** February 11 – 15, 2020
- + **METAV, Düsseldorf / Germany:** March 10 – 13, 2020
- + **Industrie, Paris / France:** March 31 – April 4, 2020
- + **Innovation Days, Chicago / USA:** April 20 – 24, 2020



Download our magazine
magazin.dmgmori.com

IMPRINT: DMG MORI TECHNOLOGY EXCELLENCE — Magazine for customers and interested parties.
Publisher and responsible for the content: DMG MORI Global Marketing GmbH,
Walter-Gropius-Straße 7, D-80807 München, Tel.: +49 (0) 89 24 88 359 00, info@dmgmori.com
Edition: 400,000 copies. Technical changes, availability and intermediate sale reserved. Our respectively applicable general terms and conditions are valid.

DMG MORI